

Terry Fox Secondary School

Course Calendar 2011/2012

1260 Riverwood Gate, Port Coquitlam, B.C. V3B 7Z5

Telephone: 604-941-5401 Fax: 604-941-1777

www.terryfox.sd43.bc.ca

TABLE OF CONTENTS

The Terry Fox Story	3
Principal's Message	3
Pursuing Excellence at Terry Fox	3
Expectation of Students & Staff	4
Mission Statement for B.C. Schools	4
School Organization.....	4
Graduation Requirements	5
Provincial Examinations	5
Scholarship and Award Information	6
Counselling Information	7
Pursuit of Excellence	7
Student Support Services	8
Online Learning.....	10
School District 43 "Programs of Choice".....	11
Transition Programs.....	15
Work Experience Programs	17
Graduation Program	19

Course Descriptions:

Art	27
Business Education	28
Planning	28
Drama	30
English	31
English as a Second Language	32
Home Economics.....	32
Information Technology	34
Languages	35
Leadership	36
Mathematics.....	36
Music.....	37
Physical Education.....	40
Science	41
Social Studies	42
Student Support Services	44
Technology Education	44

Post Secondary and Student Planning:

Post Secondary Education Information including University and College Admission Requirements.....	48
---	----



*"I wanted to try the impossible and
show it could be done."*

Terry Fox

2011-2012 COURSE INDEX

-Gr 10,11,12 courses are 4 credits each.

-Note: BAA=Board Authority Authorized,

FNA= Fine Arts, ASK= Applied Skills

ART (VA=Visual Arts; SA=Studio Arts)

1000-Art 9
1020-Media Arts 9
2020-VA 10: Media Arts (FNA)
1010-Ceramics 9
2000-Visual Arts 10:General (FNA)
3000-Art Foundations 11 (FNA)
3030-Studio Arts: Drawing & Painting 11 (FNA)
3010-SA: Ceramics/Sculpture 11 (FNA)
3050-SA: Printmaking & Graphic Design 11 (FNA)
3020-VA: Media Arts 11 (Film making)(FNA)
4020-VA: Media Arts 12 (Film making)(FNA)
4025-Animation 12 (BAA)
3051-Photography 11 (BAA)
4000-Art Foundations 12 (FNA)
4030-Studio Arts: Drawing & Painting 12 (FNA)
4010-SA: Ceramics/Sculpture 12 (FNA)
4050-SA: Printmaking & Graphic Design 12 (FNA)
4055-Photography 12 (BAA)

BUSINESS EDUCATION

1920-Keyboarding 9
1900-Business Education 9
1910-Business ComputerTechnology 9
7250-Planning 10
7255-Planning 10 X block
3950-Accounting 11 (ASK)
4950-Accounting 12 (ASK)
4957-Financial Accounting 12 (ASK)
3920-Keyboarding 11 (BAA) (ASK)
3927-Business Computer Applications 11 (ASK)
3910-Marketing 11 (ASK)
4910-Marketing 12 (ASK)
4330-Economics 12 (ASK)
4930-Entrepreneurship 12 (ASK)

DRAMA

1070-Drama 9
2070-Drama 10: General (FNA)
3070-Theatre Performance: Acting 11 (FNA)
4070-Theatre Performance 12:Acting (FNA)
3074-Theatre Production 11 (Stagecraft) (ASK)
4074-Theatre Production 12 (Stagecraft) (ASK)
4071-Directing +Script Dev't 12 (FNA)

ENGLISH

1100-English 9
1102-Honours English 9
2100-English 10
2102-Honours English 10
3100-English 11
3102-Honours English 11
4100-English 12
4102-Honours English 12 AP
4120-Literature 12 AP
6512-Honours English 12 AP + Literature 12AP
3110-Communications 11
4110-Communications 12

ESL

5000-ESL Beginners (non-credit)
5010-ESL General Skill Building (non-credit)
5040-ESL Humanities 9/10 (non-credit)
5101-ESL Canadian Studies 10
5150-ESL Skills (10)
5250-ESL Skills (11)
5201-ESL Composition 11
5260-Communications 11 A & B
5300-Communications 12 A & B

HOME ECONOMICS

1720-Textiles 9
3720-Textiles Studies 11 (ASK)
4720-Textiles Studies 12 (ASK)
1730-Textile Arts & Crafts 9
3725-Textile Arts & Crafts 11 (BAA) (ASK)
3710- Family Studies 11/12 (ASK)
3715- Child Development 11/12 (BAA)

3750-Tourism 11 (ASK)
4750-Tourism 12 (ASK)
1740-Foods and Nutrition 9
3740-Food Studies 11 (ASK)
3741-Culinary Arts International 11 (BAA)(ASK)
4740-Food Studies 12 (ASK)

INFORMATION TECHNOLOGY

1950-Information Technology 9
3975-ICT:Computer Programming 11 (ASK)
4975-ICT:Computer Programming 12 (ASK)
3980-ICT:Digital Media Development 11 (ASK)
4980-ICT:Digital Media Development 12 (ASK)
3985-ICT:Modular Survey Course 11 (ASK)
4985-ICT: Modular Survey Course 12 (ASK)
3960-Yearbook 11 (BAA) (FNA/ASK)
4960-Yearbook 12 (BAA) (FNA/ASK)

LANGUAGES

1500-French 9
2500-French 10
3500-French 11
4500-French 12
1550-Mandarin Chinese 9
2550-Mandarin Chinese10
3551-Beginners' Mandarin Chinese 11
3550-Mandarin Chinese 11
4550-Mandarin Chinese 12
1520-Spanish 9
2520-Spanish 10
3521-Beginners' Spanish 11
3520-Spanish 11
4520-Spanish 12

LEADERSHIP

5350-Leadership 9
5400-Leadership 11 (BAA)
5450-Leadership 12 (BAA)
5475-Athletic Leadership 12 (BAA)

MATHEMATICS

1200- Math 9
1220-Math 9 Essentials
2220-Apprenticeship + workplace Math 10
2204-Foundations of Math + Pre-calculus 10
3220-Apprenticeship + workplace Math 11
3200-Foundations of Math 11
3240-Pre-calculus 11
4200-Principles Math 12
4240-Calculus 12

MUSIC

1080-Band 9
2080-Music 10; Concert Band (FNA)
3080-Instrumental Music 11: Concert band (FNA)
4080- Instrumental Music 12: Concert band (FNA)
1083-Jazz Band 9
2081-Jazz Band 10 (FNA)
3081-Jazz Band 11 (FNA)
4081-Jazz Band 12 (FNA)
1090-Choir 9
2090-Choir 10 (FNA)
3090-Choir 11 (FNA)
4090-Choir 12 (FNA)
1091-Vocal Jazz 9
2091-Vocal Jazz 10 (FNA)
3091-Vocal Jazz 11 (FNA)
4091-Vocal Jazz 12 (FNA)
1082-Beginning Guitar 9 - 12
3082-Intermediate Guitar 9-12 (FNA)
3093-World Beat 11; Drumming (BAA) (FA)
1081-Rock School 9 (Contemporary Music)
2085-Rock School 10 (Cont music)(BAA) (FNA)
3085-Rock School 11 (Cont music) (BAA) (FNA)
4085-Rock School 12 (Cont music) (BAA) (FNA)
1086-Recording Arts & Sciences 9
2086-Recording Arts & Sci 10 (BAA) (FNA/ASK)
3086-Recording Arts & Sci 11 (BAA) (FNA/ASK)
4086-Recording Arts & Sci 12 (BAA) (FNA/ASK)

PHYSICAL EDUCATION

1620-Physical Education 9Girls
1610-Physical Education 9Boys

2620-Physical Education 10Girls
2610-Physical Education 10Boys
3600-Physical Education 11
4600-Physical Education 12
3631-Fitness: (Aerobics) BAA
4631-Fitness: (Aerobics) BAA
1415-Weight Training 9
2650-Weight Training 10 (BAA)
3650-Fitness 11 (Weight Training) BAA
4650-Fitness 12 (Weight Training) BAA
3632-Fitness 11 (Fit for Life)
3635 -Fitness 11 (Football) BAA
3640-Fitness 11 (Basketball) BAA

SCIENCE

1400-Science 9
2400-Science 10
7815-Science Co-op (3412 Bi 11/ 3426 Chem. 11)
7900-Science Co-Op IDS Bi 12
7890-Work Experience for Science Co-Op
3410-Biology 11
4410-Biology 12
3420-Chemistry 11
4420-Chemistry 12
3450-Earth Science 11
3460-Astronomy 11
4450-Geology 12
3430-Physics 11
4430-Physics 12
3480-Science & Technology 11

SOCIAL STUDIES

1300-Social Studies 9
2300-Social Studies 10
3300-Social Studies 11
3302-Social Studies 11 Honours
3305 -Civics 11
4350-History 12
4310-B.C. First Nations 12
4320-Comparative Civilizations 12
4340-Geography 12
4360-Law 12
4370-Psychology 12 (BAA)
4375-Social Justice 12

TECHNOLOGY EDUCATION-

1800-Technology 9
2810-Technology 10 Electronics (ASK)
2800-AppliedTechnology Education 10 (ASK)
2850-Technology 10: Drafting & Design 10 (ASK)
3850-Drafting & Design 11 (BAA) (FNA/ASK)
4850-Drafting & Design 12 (ASK)
4852-Drafting & Design 12: Architectural (ASK)
4853-Drafting & Design 12: Engineering (ASK)
4854-Drafting & Design 12: Technical Visualization (ASK)
2860-Technology Education: Woodwork 10 (ASK)
3860-Carpentry & Joinery 11 (ASK)
4860-Carpentry & Joinery 12 (ASK)
4865-Carpentry 12: Cabinet Construction (ASK)
4863 + 4864-Ace-it Carpentry 2A + 2B
4866 + 4862-Ace-it Carpentry 2C + CJR 12
3815-Mtl 11 (Art Metal & Jewelry) (BAA) (FNA)
4815-Mtl 12 (Art Metal & Jewelry) (BAA) (FNA)
3830-Metal Fabrication & Machining 11 (ASK)
4812-Metal Fabrication & Machining 12 (ASK)
4831-MF&M 12: Advanced Fabrication
4816-MF&M 12: Advanced Welding
2840-Technology Education 10: Mechanics
3821-Auto Maintenance 11 (BAA) (ASK)
3820-Automotive Technology 11 (ASK)
4820-Automotive Technology 12 (ASK)
4822-Auto 12 (Engine + Drive) (DbI Block) (ASK)
4823-Auto 12 (Electricity) (DbI Block) (ASK)-
4825 -Ace-it Mechanics 2A + 2B- 4826
4827 -Ace It Mechanics 2C+ 2D- 4828

PEER TUTORING

Application needed

WORK EXPERIENCE COURSE

Application needed

SCHOOL APPRENTICESHIP

Application needed

THE TERRY FOX STORY

One morning in March of 1977, Terrance Stanley Fox, eighteen, could not get out of his bed because of a searing pain in his right knee. The night before at his high school, Terry Fox had circled the track despite this same pain. He thought at the time it was a cartilage problem, but he didn't want to quit during the basketball season: he was a guard on the freshman basketball team at Simon Fraser University in Burnaby, British Columbia, a position he had earned through hard work and skill. On that morning in March, in the small, ranch-style home in Port Coquitlam, the pain was too great to move. His father, Rolly Fox, took him for a thorough medical examination. After a series of tests a doctor walked into Terry's hospital room, and, with his parents standing by, Terry was told he had osteogenic sarcoma of the right knee, the most common form of a rare bone cancer. The leg must be amputated, and as soon as possible, because the cancer was dangerous and would spread quickly. At the age of 18, the tragedy was enormous.

This was the Terry Fox who at first couldn't make the grade 8 basketball team, but who had practiced so long and so hard that he was named athlete of the year, when he graduated from "Poco" - Port Coquitlam High. This was the Terry Fox who had applied himself with equal diligence to his studies, achieved straight A grades and gained admission to university. The night before the operation, three days after the diagnosis, his former basketball coach came to see him with an article about a one-legged runner who had finished the New York Marathon. "I had a dream that night", Terry was to say many times, throughout his marathon, "that I would run right across Canada". Terry was up six weeks after the operation and soon began playing eighteen holes of golf. After 16 months there was no evidence of new cancerous growth. During his hospital convalescence he saw much tragedy and pain in the

cancer wards of the Royal Columbian Hospital in New Westminster, B.C.. In his letter to the Cancer Society about his proposed run, he wrote, "Somewhere the hurting must stop."

Terry's run began April 12, 1980 when Terry dipped his artificial leg into the Atlantic Ocean. After completing his progress through the Maritimes, Quebec and into Ontario, Terry was forced to stop September 2, 1980 in Thunder Bay.

During this short period, Terry captured the hearts of a nation and to say it simply, he caught the essential spirit of what man can be. Terry died June 28, 1981. Terry's dream continues as the Marathon of Hope is an annual event every September in an effort to raise money for cancer research.

Port Coquitlam Senior Secondary School was very proud to honour this courageous graduate by renaming the school, Terry Fox Senior Secondary on January 18, 1986.

"I want to set an example that will never be forgotten. It is courage and not foolishness."

~ Terry Fox

Welcome to Terry Fox

This school is dedicated to the memory of Terry Fox. The students and staff of Terry Fox Secondary are deeply honoured to be identified with the ideals and concern for others that Terry Fox exemplified. Terry was an ordinary teenager; he was proud of his school and shared the same joys and sorrows, the same hopes and uncertainties as all his friends at PoCo. Terry never presumed to set standards for others and always did his best. Because of his dedication to his own demanding goals, Terry's life has become an inspiration to us all.

It is with this spirit of dedication to our goals and determination to do our best that we, at Terry Fox

Secondary, will strive to pursue excellence.

PRINCIPAL'S MESSAGE

Welcome to Terry Fox Secondary School. We offer a comprehensive program of courses leading to graduation in a variety of specialties including Academic, Advanced Placement, Business Education, Drama, Technology Education, Home Economics, Music, Visual Arts, Computer Science, Physical Education, Transition Education and two Apprenticeship Programs: Automotive Service Technician & Carpentry. These programs provide a challenge to students and enable them to specialize and excel in an area of interest. We provide our students with up-to-date computer support for their learning activities. Our Learning Centre, Skill Development Program, Career Centre and Online opportunities provide added service to students wishing help.

We encourage each student to take full advantage of the many opportunities provided. As students of Terry Fox, we hope that you will show the dedication, determination and courage which will lead to successful graduation.

Ms. H. Murphy, Principal
Mr. G. Conley, Vice-Principal
Mr. J. Hyde, Vice-Principal
Mr. R. Jacobsen, Vice-Principal

PURSUIING EXCELLENCE at TERRY FOX

In all areas: Academics, Vocational, Extra- and Co-Curricular

Acceptance and Integration
Advanced Placement
Amnesty International
Athletic Program
Band/Choral Performances
CAD Awards
Transition Education Programs
Career Week
Christmas Hamper Drive
Computer Excellence
District Scholarship Winners

Drama - Plays and Musicals
 Dry After-Grad
 ESL Program
 Essay Contests
 Fashion Show
 Financial Aid
 Fine Arts Evening
 House of Commons Page Program
 International Exchange Students
 Math Awards
 Multicultural Club
 On Line Learning
 Provincial Scholarship Winners
 Provincial Sport Championships
 Public Speaking Contest
 Sport and Cultural Exchange Trips
 Terry Fox Run
 Toy Drive
 UNICEF Fund Raising

ATHLETICS

Athletics have been an integral part of the extra-curricular program at Terry Fox since the school opened its doors in 1959. The school is a member of the Coquitlam Secondary School Athletic Association and participates in the Fraser Valley Athletic Association for qualification to provincial championships. To date Terry Fox has 10 Provincial title winners: 3 Sr. Football, 2 Jr. Football, 2 Sr. Boys Basketball, Jr. Boys Basketball, Gr. 9 Boys Basketball and Cheerleading. We are very proud of our athletes and the tradition of excellence that they have established throughout the province over the years. Our extra-curricular program includes competition in the following sports:



Basketball
 Cheerleading
 Cross-Country
 Field Hockey
 Football
 Golf
 Lacrosse
 Rugby
 Soccer
 Skiing/Snowboarding

Swimming
 Tennis
 Track and Field
 Volleyball
 Wrestling

EXPECTATIONS OF STUDENTS AND STAFF AT TERRY FOX SECONDARY

Expectations of students and staff at Terry Fox Secondary School are derived from the Mission Statement for schools in British Columbia, the district and school Codes of Conduct and from the Roles and Responsibilities established for all participants in the school system as outlined in the provincial Mandate:

“The purpose of the British Columbia school system is to enable all learners to develop their individual potential and to acquire the knowledge, skills, and attitudes needed to contribute to a healthy, democratic, and pluralistic society and a prosperous and sustainable economy.”

ROLES AND RESPONSIBILITIES

“Schools are responsible for involving students in provincial and locally developed education programs in accordance with provincial and district policy. At the school level, teachers and administrators are responsible for organizing educational programs that meet the needs of each student, for assessing and evaluating student learning, and for communicating with parents about student progress.”

“Students are responsible for making the most of their educational opportunities, for respecting the rights of others, and for co-operating with fellow students in the achievement of their personal goals. Parents are responsible for providing the healthy and supportive environment that is necessary for their children to learn, for helping to shape the school system’s goals, for supporting those goals, and for sharing in the task of educating their children. The community is responsible for supporting the school and family by providing children with a

healthy and supportive community environment. Terry Fox Secondary School is organized and operated on the assumption that students attend out of their desire to do so and with full understanding of their responsibilities.

Terry Fox students are expected to accept personal responsibility for learning, for attending classes, for completing assignments on time and for respecting the rights of others. We expect that our teachers will offer quality instruction, will encourage students to cooperate in the learning activities of the school, and will respect the rights of students. It is only with a sincere effort on the part of everyone connected with our school - students, teachers, counsellors, teaching assistants, the principal, vice-principals, secretaries, caretakers, cafeteria staff, parents, and friends - that we can hope to maintain an atmosphere characterized by trust, caring and understanding.

Subject matter at this level can be very challenging. In order to be successful, students must be prepared to spend time out of class doing homework and studying. Most students must be prepared to spend two hours per day in out-of-class preparation.

In order to meet the requirements of Bill 33 the school is required to control the size and composition of all classes. These restrictions limit the flexibility to make course changes to student’s timetables.

We are confident that all students can and will meet these expectations.

SCHOOL ORGANIZATION

SEMESTER SYSTEM

At Terry Fox Secondary, the school year is divided into two, five month semesters. Most courses are one semester long and meet for 70 or 75 minutes each day. Some courses like Music are exceptions. These courses run on alternate days for the entire

school year and are called linear classes. The combined English 12/Literature 12 course also runs the full year. Students in grades 9 – 12 will complete eight courses each year.

SCHOOL DAY

Students are assigned to classes with the assistance of a computer program. The school day runs from 8:00 a.m. to 3:20 p.m. and it is expected that students will be available to attend school during those hours.

REPEATING COURSES TO UPGRADE MARKS

Hoping to improve a mark, students may request permission to repeat a course that they have already passed. Students should see their counsellors for a “Request to Repeat a Course” application form. Administrators and counsellors consult with teachers about the applications and then meet to determine which students will be given the opportunity to repeat the course. Students are assigned a seat if there is space in the course.

ATTENDANCE

As the final standing for each course is based on class assignments and examinations during the semester, regular attendance at Terry Fox is essential. Students who are absent or late are responsible for completing the work of the course to the satisfaction of the teacher.

Parental permission is requested for all absences. Parents are asked to either log the absence online at our website or contact a secretary by calling the main office at 604-941-5401 to report excused absences. Students who are going to be absent for an extended period of time should have their parents advise the school so that home study can be arranged.

COURSE FEES

- While the District supports the philosophy that an educational program and resource materials be provided free of charge to every student of school age, a resident in the District and

enrolled in an educational program in a District school, the District also believes that there are instances when it is appropriate that a fee be charged for goods or services, or when materials should be provided by a student's home.

- The District authorizes charges for optional curricular and extra-curricular activities, transportation or other goods and services provided by the District in order to enrich curricula and school life for students. The District also supports the provision from home of basic supplies or materials (e.g. pencils, pens, notebooks, running shoes). In addition, the District believes parents must be informed of the process whereby fees may be waived.
- The Board will not charge any course fees. Basic course supplies required to meet the learning outcomes must be provided free of charge.
- On a cost-recovery basis, schools may continue to charge fees for optional activities, supplies for optional or enhanced projects or services such as yearbooks, athletics, extra-curricular activities and travel, optional field trips and graduation activities (cap and gown, dinner/dance and after grad).
- Student activity fees will be charged for student agendas, student leadership activities, clubs, cultural performances and special events and student activities organized by the school.
- Students participating in a music class, course or program or a fine arts class, course or program with a music component, will be charged fees for the purchase or rental of a musical instrument for student's personal use or the student will be required to provide their own instrument.
- Certain school courses and programs offer the opportunity for students to acquire certification in areas such as First Aid, CPR, Food Safe and Super Host. There

certifications are not curriculum requirements and student participation is optional. Students will be charged a fee to cover the cost of the certification cost if they choose to obtain it.

- Schools may charge fees for optional field trips that enhance and add value to a student's classroom learning experience.

GRADUATION REQUIREMENTS

SCHOOL COMPLETION CERTIFICATE

In the spring of 2006, the Minister of Education made a commitment to maintain the Ministry of Education's role in issuing School Completion Certificates. Along with this was the pledge to produce transcripts for students who are issued School Completion Certificates. School Completion Certificates are intended to recognize the accomplishments of students, including students with special needs, who have succeeded in meeting the goals of their educational program other than graduation. All students, including those with special needs, in receipt of School Completion Certificates will now also receive a transcript of successfully completed work in Grades 10 to 12. Completed work may include both Graduation Program courses and locally developed courses.

GRADUATION PROGRAM EXAMS

Students are required to write at least five provincial exams. Exams are mandatory for the following subject areas:

- Grade 10 Language Arts
- Grade 10 Science
- Grade 10 Mathematics
- Social Studies 11 or 12
- Grade 12 Language Arts

Exam results are blended with the classroom mark to generate the final course mark. Grade 10 and 11 exams count for 20% of the final mark. Grade 12 exams count for 40% of the final mark. The above exams are

mandatory. All other Grade 12 exams are optional. If you chose to write an optional Grade 12 exam, it counts for 40% of the final mark. Your classroom work counts for 60%. Please note: Some post-secondary institutions require Grade 12 exam scores for entrance. Writing Grade 12 exams can also mean you qualify to win provincial scholarships. Consider these facts carefully as you plan your courses over the next three years.

Graduation Program exams can be written in January and June. Not all Grade 12 exams will be available in all sessions. Students and their parents are advised to pay close attention to the printed regulations provided by the Ministry and the school with respect to examination schedules and locations.

Parents are advised to contact the school prior to planning any vacation near the end of a semester, as graduation program exam dates cannot be changed to satisfy individual situations.

The Ministry of Education will post examination results and final letter grades on their web site. Students can access this information with their Personal Education Number (PEN) which is available at the school for students. Appeals against the provincial portion are to be directed in writing to the Ministry of Education.

Students who fail examinable subjects may:

1. repeat the course and write the examination again, or
2. rewrite the examination within one year without repeating the course (in which case the school mark will stand and will be combined with their highest examination mark to form their final mark). Any students wishing to re-write an exam must register in the main office well in advance of the exam date.

Access to exam information by going to the Ministry web site:
<http://www.bced.gov.bc.ca/exams>

Students should be aware that graduation from high school does not automatically guarantee entrance to a specific institution. Students are responsible for investigating post secondary institution requirements.

ADJUDICATED EXAMS

Students who have documented histories of intervention by Student Services for a learning disability as determined by psycho-educational testing approved by the Ministry, or on School Completion Certificate Programs, may receive Ministry granted accommodations when writing provincial exams. Specific accommodations allowed are determined by testing results and evidence of prior support, and may include: extra time, separate setting to write in, use of audio tapes or computers to write exams, use of spell checkers or text to voice / voice to text software, or reader / scribe services. Eligibility information and application for this accommodation is processed through the Learning Center.

EXTERNAL COURSES/CREDITS

www.bced.gov.bc.ca/graduation/crsinfo/contents.htm

The Ministry will accept External courses, an organized set of learning activities developed or offered outside the British Columbia School System, as a Ministry authorized course. For more detailed information students should contact their counsellor. Some courses that may be of an equivalent standard to other Ministry authorized senior secondary courses include:

- **Music:** BC Conservatory of Music, Conservatory Canada, Royal Conservatory Music, Victoria Conservatory Music, Trinity College-London
- **Dance:** Jazz, Cecchetti, Tap, Modern Theatre Dance, Royal Academy of Dancing
- **Drama, Speech and Effective Communication:** Trinity College: Drama, Effective Communication and Speech and Drama

- **Post Secondary:** Various courses including Douglas College Math 120, Interdisciplinary Studies 110, Anthropology 160, Math 160, Psychology 100 & 102, Sociology 135 & 125.
- **Languages:** challenge, equivalency and external language credit
- **Sports:** Athlete, Coach, Official Youth Development: Cadets, 4-H, Guides, Scouts
- **Industrial and Occupational:** Tourism, Wood products, Lifesaving, Red Cross Water Safety Instructor, First Aid, Computer Certification, ICBC Driver Education, Canadian Private Pilot's License

DAILY PHYSICAL ACTIVITY

Daily physical activity (DPA) refers to physical activities that help develop endurance, strength, and flexibility. Implemented in September 2008, students are required to document and report their activity as part of their academic program. Grade 9 students are responsible for participating in 30 minutes of daily offered activities. Grades 10, 11, and 12 students must record at least 150 minutes a week as part of their Graduation Transition program.

SCHOLARSHIP AND AWARD INFORMATION

A great deal of financial help is available to students. In most cases, the awards are available on condition that a student is proceeding to further education. In a few cases, the award is a prize for excellent achievement.

Information concerning scholarships is available to Grade 12 students early in the school year. The Counselling Department assists students in the preparation of applications for scholarships. Interested students are encouraged to attend the scholarship workshop early in October to obtain detailed information.

District Scholarships and Awards are awarded to acknowledge excellence in non-academic specialty areas.

Provincial Government Scholarships are awarded for academic excellence. Students must take at least three government exams to qualify. A large number of additional scholarships are available for students of this school. Parents and students are urged to check with their place of employment, union, lodge, life insurance company, banking institution, club, or any other organization with which they may be (or have been) associated. Many organizations are very generous in this regard. Many of these local or special scholarships do not depend on government examinations.

PASSPORT TO EDUCATION

The Passport to Education Program recognizes and rewards student achievement in Grades 10 to 12 in a broad range of academic and non-academic areas according to guidelines set out by the Ministry of Education. The intent of the program is to motivate all students to study consistently during the years leading to graduation, and to encourage secondary school students to pursue further education through post-secondary institutions and job-training programs. Passport awards are used to further students' post-secondary education and job training.

The passport booklet is kept in a file until graduation or a student leaves the school. Students are informed if they are the recipient of a passport stamp. Upon graduation the booklets are available for pick up to be used towards post-secondary education.

HONOURS STANDING ON TRANSCRIPTS

If a student has completed graduation requirements and obtained a Grade Point Average (GPA) that is greater than 3.0 (a better than B average) as determined by the Ministry, the student's Transcript will include the phrase "...with Honours Standing". The Ministry calculates Grade Point Average based on the best 80 credits that satisfy the Foundation Studies and Selected Studies requirements for

graduation. Courses completed for less than 4 credits are weighted to reflect their credit value. The grade point scale used is set out below:

A (86%+) = 4 points; B (73-85%) = 3 points, C+ (67-72%) = 2.5 points, C (60-66%) = 2 points, C- (50-59%) = 1 point

SCHOOL HONOUR ROLL

To receive honours standing a student must receive **a 3.25 or better grade point average**. A = 4 points; B = 3 points, C+ = 2.5 points, C = 2 points, C- = 1 point.

At each reporting period we celebrate and recognize the achievement of our students. Take note that **official Honour Roll standing is calculated at the end of each semester**.

SCHOOL HONOURS WITH DISTINCTION

Criteria: 3.5 – 3.99 GPA calculated in all courses throughout the year.

SCHOOL HONOURS WITH GREAT DISTINCTION

Criteria: A 4.0 GPA in every course throughout the year.

SCHOOL HONOUR GRADUATION PINS

A student must have been on the Honour Roll for each semester in **ALL** four years of secondary school.

COUNSELLING INFORMATION

Students are assigned to counsellors on an alphabetical by last name basis. Students wishing to see a counsellor should go directly to the counsellor's office. If a parent has any questions concerning the program, progress, or attendance of a student, please contact a counsellor at 604-941-5401.

GENERAL SERVICES INCLUDE:

- Help in program and course selection.
- Help in solving academic difficulties and problems, in arranging for tutorial assistance, and in improving study skills.

- Information about the school and its functioning - orientation.
- Information on post-secondary training and registration (universities, regional colleges, vocational schools, technology institutes, apprenticeship programs, etc.), and on transition to such training.
- Information on vocational and career planning, family life, intellectual skills (learning styles, learning disabilities, study skills), relationships, child/sexual abuse, substance abuse, mental well being and healthy living.
- Discussion of personal problems and assisting students in making their own personal decisions.
- Support in crisis situations and referral to community agencies (mental health, counselling, public health, social services, etc.).
- Career Resource Centre.

LINK CREW

Link Crew is an orientation program that trains selected members of the grade 11 and 12 class to act as team leaders, motivators, role models and teachers. Their role is to introduce new grade 9 students to the climate and culture of Terry Fox during an orientation event and to provide support to their grade 9 "crew" throughout the year. Link leaders are nominated by their teachers who are asked to select students displaying positive leadership characteristics. Senior students may also indicate interest by speaking to their counsellors. Scholarships are available to members

PURSUIT OF EXCELLENCE

ENRICHMENT PROGRAMS

The secondary curriculum offers challenging programs for students. Students may specialize in a number of subject areas by taking two or more courses in one academic subject area. Advanced Placement is a program of college-level courses and examination for academically talented students. Essentially, opportunities include

acceleration and enrichment, which allows gifted and motivated students to begin their college or university studies while still in secondary school. Enrichment is possible without sacrificing extra-curricular activities and is a useful complement to the scholarship program at Terry Fox Secondary School. Academic and personal support for gifted/motivated students and their teachers is available via Student Support Services and Counsellors.

Courses that may be of interest to highly motivated students include:

- Science 9/10
- All courses indicated as Enriched or Honours
- Advanced Placement Courses
- Online Courses
- Work Experience Programs
- Secondary Apprenticeship Programs
- Course Challenge
- Science Co-op
- ACE IT Program

ADVANCED PLACEMENT PROGRAM

Advanced Placement is a program of college level courses and exams for secondary students developed by the U.S. College Board in Princeton, New Jersey. It gives high school students an opportunity to receive advanced placement and/or first year credit in college and/or university. Students prepare for the AP exam by taking an Advanced Placement class.

Satisfactory grades on AP Examinations may offer many benefits. Advanced Placement in college or university allows you to skip work you've already done in high school and move on to higher-level courses. You will also gain time to explore subject areas that you wouldn't otherwise be able to study. The basic reason for taking an AP course, however, is to learn a subject in greater depth, to develop analytical reasoning skills, and to develop disciplined study habits

appropriate for continued success at the post-secondary level.

Advantages of the Advanced Placement Program

In addition to the advantages mentioned, another advantage of taking AP courses would be a student may select a single course or a combination of courses. This allows for:

- A gradual acclimatization to collegiate work load and pace.
- Enrichment without sacrifice of extracurricular activities.
- Students are able to decrease their time spent in the university lab by as much as two thirds due to their confidence and experience gained in their AP classes.
- Excellent preparation for both provincial as well as many external scholarship exams.

Advanced Placement at North American Universities

Some B.C. institutions that recognize the AP program are:

- Okanagan University College
- University of B.C.
- Simon Fraser University
- University of Northern B.C.
- University of Victoria

Many institutions outside of B.C. recognize the AP program such as:

- University of Manitoba
- McGill University
- University of Toronto
- University of Alberta
- Most U.S. Colleges

CHALLENGE

Course challenge is the process of receiving credit for a Ministry-Authorized or Locally Developed Grade 11 or 12 courses taught within the school district, through an assessment of a student's undocumented prior learning. The process of Challenge is meant to be rigorous, maintaining the integrity of the curriculum and the standards of a quality education. A student is entitled to challenge a course if he or she:

- is currently enrolled in the school district, or is currently registered as a home schooler, or is enrolled in the Distance Education school where the challenge is being requested.
- has not completed the course through previous enrolment.
- can give compelling evidence that he or she will succeed in the challenge.
- shows that the challenge is linked to his or her Student Learning Plan.

Courses possible to challenge at this time in School District #43 Coquitlam:

- French 11/12
- German 11/12
- Japanese 11/12
- Mandarin 11/12
- Punjabi 11/12
- Spanish 11/12

For more information contact a counsellor of Terry Fox.

STUDENT SUPPORT SERVICES

Terry Fox Secondary offers a variety of support options to meet the special learning needs of students whose skills, interests, and / or abilities lie outside those of average students. Where possible these services are provided within regular subject classrooms; however, depending on student needs, support may be provided via the Learning Centre or Skill Development classrooms.

Student Services provides support to students with diagnosed learning disabilities and, where space permits, others who are experiencing difficulties in their courses with academic / behavioural / motivational / life skills support to enable them to develop the academic and personal skills needed to function successfully in a regular classroom and life. Teamwork among students, teachers, parents and support staff is a vital component of reaching student success. Support can include:

- In consultations, writing Individual Education Plans (IEP) outlining each supported student's program for teacher reference

- Consultation to teachers / departments / parents about appropriate in-class support for students and advocacy for the needs of students with learning disabilities in regular classes
- Provision of adapted or modified course materials / strategies for class teachers and students to use in regular classes or Learning Centre (e.g. taped novels, alternate texts or units, study guides)
- Monitoring of academic progress and attendance in regular classes
- Diagnostic testing and referrals to other testing or support agencies
- Alternate setting for students who qualify for Adjudicated Exams* (see below)

Specific courses / supports available for students with learning disabilities / special needs are listed toward the back of this book in the Student Services section.

LEARNING CENTRE

The Learning Centre program enables students who are experiencing difficulties in their courses to receive academic and/or behavioral attitudinal-support via one to one or small group remedial teaching. Emphasis is placed on academic skill development, class assignment completion, test preparation, individualized programs for students with demonstrated learning disabilities; and advocacy for students

with diagnosed learning disabilities. Diagnostic testing and referrals to other testing or support agencies are available. The Learning Centre also provides an alternate setting and support for students requiring adjudicated exams.

Courses provided for support of students with special needs are listed toward the back of this book in the Student Support Services section.

SKILL DEVELOPMENT PROGRAM

The Skill Development class offers integrated instruction at the secondary school level in academic and life skills for students with identified specific needs. Access to this program is via District #43 screening only. Individual Education Programs may include opportunities for participating in work experience.

IN SCHOOL SUPPORT (ISS)

The program provides students who are at school each day but are not attending one or more classes for a variety of reasons an opportunity to receive academic credits via an individualized learning program. This program benefits those students who need to form a one-to-one connection with an adult before they are comfortable regularly attending classes. The intent is to have students who are participating in the program to

eventually be reintroduced back into regular classrooms. Students are eligible to participate via a referral from School Based Team.

ENGLISH AS A SECOND LANGUAGE

The ESL Program provides English language training, background knowledge and cultural adjustment support for students whose first language is not English. The Program is designed to help students acquire the English language skills that will enable them to be successfully integrate into the regular school stream. All students who are new to Canada, and whose first language is not English, will be given a language proficiency assessment. Based on the results, all students who are new to Canada, and who demonstrate a need for extra English instruction, are required to enroll in ESL classes. ESL teachers, in consultation with the Counselling and English Departments, will make recommendations for course placement.

ESL courses that provide support for students new to Canada are listed toward the middle of this book.



Online Courses at Coquitlam Open Learning

Do you want to take more than 8 courses?
 Would you like to have more elective blocks at your school?
 Do you want to take a course your school does not offer?

If you answered yes to any of these questions then you should consider taking a course at Coquitlam Open Learning (COL). COL is School District #43's online school and offers flexible-pace, continuous entry courses for all Tri-City students. *COL works with your school to provide you with the seamless educational program you need.* Also, COL has designated support teachers in every SD43 secondary school to help you get started with and succeed in your online course.

If you think you would like to take a course online now or next year, talk to your counsellor.

Learn Your Way

Coquitlam Open Learning offers several types of learning environments, allowing you to choose the course format that works best for you:

Online Blended – These courses will have specific start dates (either first semester, second semester or full year) and you are required to attend some regularly scheduled classes, with most of the course being completed online. Students are required to travel to specific schools for face-to-face sessions which will be held up to once a week, outside of the regular school day. The *face-to-face* classes will be used for seminars, group discussions, labs, and extra support.

Online – These courses allow students to enter at any point between September and March (no new registrations after spring break) and are *flexible-paced*. As these courses are designed to support students in day-schools, they end in June and must be completed by that time. Students registering for one of these courses must be prepared to do the majority of communication with their teacher using online tools, such as email and chat.

Learning Centre – These courses are offered at our drop-in learning center, CLOC, near Coquitlam Center. These courses allow students to enter at any point during the year and are *self-paced*. Depending on the course and student preference, these courses could be either online or paper-based.

Language Labs – COL offers language programs in French, Spanish, Mandarin and Japanese. Our Language Labs offer optional weekly drop-in support at Gleneagle combined with the best computer-based instruction using Rosetta Stone language software.

How to Register

Check out our course offerings listed here. **After a discussion with your counsellor, you can also visit the DL support teacher in your school for more help on registering for COL.** For more information or to register, visit our website at <http://online.sd43.bc.ca>

Course	Online	Online-Blended	Learning Centre
Accounting 11			CLOC
Accounting 12			CLOC
Animation 12		Heritage	
BC First Nations 12		Pinetree	
Biology 11			CLOC
Biology 12			CLOC
Business Computer Applications 11			CLOC
Calculus 12			CLOC
Career and Personal Planning 12 A			CLOC
Chemistry 11			CLOC
Chemistry 12		Pinetree	CLOC
Communications 11			CLOC
Communications 12			CLOC
Comparative Civilizations 12			CLOC
Computer Networking (Cisco CCNA)		Riverside	
Data Management 12			CLOC
Drafting 11/12		Riverside	
Earth Science 11			CLOC
English 10	Anywhere		
English 11	Anywhere		CLOC
English 12	Anywhere		CLOC
Family Studies 12			CLOC
French 11	Language Lab		
French 12	Language Lab		
Geography 12			CLOC
History 12			CLOC
Japanese 11	Language Lab		
Japanese 11 Intro	Language Lab		
Japanese 12	Language Lab		
Law 12			CLOC
Literature 12	Anywhere		
Mandarin 11	Language Lab		
Mandarin 11 Intro	Language Lab		
Mandarin 12	Language Lab		
Marketing 12			CLOC
Math 10 Apprenticeship & Workplace			CLOC
Math 10 Foundations & Pre-Calculus	Anywhere		CLOC
Math 11 Essentials			CLOC
Math 11 Principles	Anywhere		CLOC
Math 12 Principles			CLOC
Math 12 Principles Upgrade		Centennial	
Physical Education 10	Anywhere		
Physical Education 11	Anywhere		
PE 12 - Fitness and Conditioning	Anywhere		
Physics 11			CLOC
Physics 12			CLOC
Planning 10	Anywhere		CLOC (Adults)
Psychology 12 (optional AP)		Riverside	
Science 10	Anywhere		CLOC
Science and Tech 11			CLOC
Secondary School Apprenticeship	Anywhere		
Social Studies 10	Anywhere		
Social Studies 11	Anywhere		CLOC
Spanish 11	Language Lab		
Spanish 11 Intro	Language Lab		
Spanish 12	Language Lab		
Work Experience 12	Anywhere (Under 19)		CLOC (Adults)
Writing 12		Gleneagle	CLOC

District Programs of Choice

Open to All Students

The following programs are offered on a limited enrolment basis in one or more secondary schools in our district. Students who have an

Advanced Placement (AP)/Honours Pinetree, Gleneagle, Centennial

These Advance Placement schools offer coordinated program of enrichment for Grades 9-12. Students will be selected for honours classes in core areas, after an application process. In the senior years, students will be prepared to enter AP (Advanced Placement) classes. These courses allow students to work together in challenging environments that will gradually acclimatize them to the rigors of university classes. This program is designed for students who are interested in attending university. The course of study allows students to work together in a rigorous and exciting learning environment.

Automotive Service Technician ACE-IT Apprenticeship

Terry Fox, Centennial

This post-secondary program is part of the Industry Training Authority ACE-IT initiative, and is open to Grade 12 students intending to pursue careers as Red Seal certified Automotive Technicians. Students completing this full semester, dual credit, four course program will receive 16 credits toward graduation and will write the Standardized Level 1 assessment exam. A 70% grade on this exam will qualify the student to progress to Level 2 training when requirements for Apprenticeship training hours are met. Work-based training will be an integral part of this program, and must be completed by September 30 of the graduation year. This program is designed for motivated students with a career focus and will provide excellent Apprenticeship placement advantages for successful students. Enrollment in this program will be limited to 18 students per year, and admission will be by application. The application process will include an interview and a review of attendance records and will

require a recommendation from the student's Automotive Technology 12 instructor. Applicants will need to have been programmed in such a way as to have completed foundation requirements by the end of the Fall semester of their Grade 12 year. Foundation: Auto Tech 11 and 12 (C+), English 12 or Communications 12, Math 11 Essentials (B) or Math 11 Principles, "L" drivers' license, working knowledge of computers.

Biology 12 AP Seminar Centennial

This Semester 2 course deals with topics in greater detail than in Biology 11 and 12. It has an extensive laboratory component which includes DNA isolation, fingerprinting and transformation experiments. Course content includes: Molecules and Cells – basic biological chemistry, cells, energy transformations (25%); Heredity and Evolution – molecular genetics, heredity, evolution (25%); Organisms and Populations - taxonomy, survey of protista, monera and fungi, plants, animals and ecology (50%). This course will aid the student in scholarship competitions and in obtaining advanced standing or credits at some universities. Foundation courses: Biology 11, Chemistry 11 and Biology 12. Biology 12 should be taken in Semester 1.

Carpentry ACE-IT Apprenticeship Terry Fox

Students will take 4 courses in Semester 2 at Terry Fox then go to Kwantlen Polytechnic University from the middle of June. Foundation courses: C in Math 11 Essentials and physical ability for the job.

Chemistry 12 AP Seminar Riverside, Centennial

This course covers material equivalent to first year university chemistry. It is an

interest in enrolling in any of these "Programs of Choice" should contact their home school counsellor for further information.

excellent preview of university chemistry and will give students an advantage in post-secondary science programs.

Foundation course: Chemistry 11 with an "A" or "B." Chemistry 12 should be taken in Semester 1.

COAST - Coquitlam Outdoor Academic School Term - Grade 10 students

Gleneagle

COAST is about personal development as much as it is about academic development. From the mountains to the sea, students are challenged to extend their learning outside the classroom. By combining academic work with field studies, leadership training, and outdoor education, we aim develop enriched connections and broad understandings to the world around us. The curriculum supports the development of independent, inquiring, life-long learners with a focus on community service. Students can look forward to a semester of building enhanced self-confidence, stronger physical fitness, and a sense of accomplishment within a supportive learning environment.

Computer Networking 11 and 12 Riverside

This program connects students in Information Technology Management with a challenging career in the computer networking field. Students are linked with both business and post secondary opportunities.

BCIT Computer Systems Network Fundamentals Riverside

The Computer Systems Network program is the initial year of a two-year diploma program covering computer hardware, operating systems,

networking, and internet technology. Upon successful completion at Riverside, students may enroll in the second-year program held at the BCIT Burnaby campus. Foundation courses: Math 12 Principles (60%), English 12 (60%).

Concurrent Studies (Douglas College and SFU)

Accepted students will be able to take several university level courses while still enrolled in high school. Courses begin in September and January. Students must see their school counsellor for eligibility and registration information.

Construction Electrician ACE-IT Apprenticeship

Best (February to January)

Students will take 2.5 courses in the second semester of Grade 11 followed by work experience in the summer. Students will take 2.5 courses in the fall of their Grade 12 year to complete the program.

Foundation courses: Math 11 and 12, Physics 11.

Cook Training 11A and 12A

Centennial, Gleneagle, Riverside

Topics of study include kitchen layout and maintenance, equipment operation, knife skills, terminology, plate presentation, Food Safe/HACCP, sauces, soups and stocks, and the Pastry Program. Cook Training 12A focuses on elaborate food items such as pates, galantines and secondary sauces as well as the use of more specialized equipment.

Cook Training ACE-IT Apprenticeship

Riverside, Centennial

Upon completion of this program, students will find excellent opportunities in the Hospitality/Tourism industry. Foundation: Completion of Planning 10.

Coquitlam Teen Parenting Program CABC

This program is designed to enable pregnant and parenting teens to

continue with their education in a supportive and flexible environment. Courses are offered in a variety of ways including self-paced, structured classes and other options. Students are able to enrol in courses at CABC or at a district secondary school depending upon program availability. Information and courses on children and parenting skills are an important aspect of the program. The YMCA Little Scholars Childcare infant and toddler program is available on site and allows parents to be actively involved with their child while continuing their education. *Please call: (604) 939-4511 for additional information.*

Dance (Performance Dance)

Port Moody, Terry Fox, Heritage Woods

Students need to be experienced dancers who display dance abilities via an audition. Focuses specifically on performance skills.

Environmental Science 9/10

Gleneagle

These programs offer a wide range of local ecology and environmental issues. This program includes a lot of lab work and field trips to community-based projects.

Experiential Studies 10

Centennial

This program will combine Science 10, Earth Science 11, Planning 10, Social Studies 10, and Physical Education 10. All curriculum requirements for these programs will be met. The program aims to extend and enrich a student's understanding of these five courses. The subjects will be taught in a manner that integrates traditional class work, science labs, projects, and field studies. The field experiences will vary from one to three day trips to one larger two-week trip. Field experiences may center on subjects like biology, geography, geology, history, etc. while doing activities such as kayaking, mountain biking and hiking. Students must attend Centennial for the entire year as there are activities and fundraising done in Semester 1.

Fish & Wildlife 12 (Fisheries Ecology 12)

Centennial

Students in this program play an important role in protecting and enhancing the local environment. Major projects involve the operation of Mossom Creek Hatchery, water quality of local streams, marine studies of harbour seals and plankton, streamside vegetation identification, small vessel operation and VHF radio certification, and environmental outreach via public fairs and visits to elementary classrooms.

Foundation course: Science 10.

French Immersion

Riverside, Charles Best

The French Immersion program has several goals that enable students to achieve, reach and become functionally bilingual.

Digital Immersion 9

Riverside

Is a program which provides grade 9 students the opportunity to use their laptop computer to facilitate learning both at school and at home. Taught by a core team of teachers the prescribed B.C. curriculum will be covered within a 21st century model of innovation and collaboration. Students in the program will stay together as a cohort for their "computer immersion" courses of English, Social Studies, Science and Digital Applications. Students interested in the program should have at least a "B" average (or current teacher recommendation) in Math, Language Arts and Social Studies, possess a strong work ethic and a high degree of responsibility. Entry into this program is by application based on teacher recommendation, parent permission and space availability. Students are expected to have their own laptop computer. Arrangements can be made for those who are unable to provide their own equipment to rent a school laptop for a nominal fee. Students will not be denied access to this program due to financial need.

Global Perspectives 12***Pinetree***

An exciting program designed to provide students with the opportunity to travel to, and participate in, a hands-on-project in a developing country, as well as develop awareness of global issues and career options in various related fields. This year long program is integrated with Career Preparation Work Experience. Students will be encouraged to develop a vision for their futures, including personal goals, career directions and educational opportunities. The targeted audience is current Grade 10 & 11 students.

**Hairdressing ACE-IT Apprenticeship
*Gleneagle***

This is a 10 month in-school training program for secondary school students to earn graduation credits and industry certification in hairdressing. Students earn 24 graduation credits through Secondary School Apprenticeship if hired as an apprentice. Students establish themselves in a career that allows them opportunities to explore other options related to the hairdressing industry.

Foundation courses: Completion of Grade 11.

**Hockey Academy
*Centennial, Riverside*****Emily Carr Headstart to Art
*Gleneagle***

Emily Carr offers high school students the opportunity to complete 3 university credits plus a portfolio review. Students must be recommended by their high school art teacher.

**International Baccalaureate
*Port Moody***

The International Baccalaureate (IB) program has been adopted as a district program to ensure that all highly motivated and talented secondary students have equal access to the opportunities provided through this internationally renowned program. This is a district wide program that offers a

coordinated curriculum from Grade 9 through Grade 12. IB includes appropriately challenging experiences in an environment of positive stimulation that comes from working within class groupings of similarly motivated and talented students.

**Italian 11 Introductory and Italian 11
*Riverside***

This course is designed for students who have little or no Italian background. It includes the study of the four language skills: speaking, listening, reading and writing. Students will learn basic vocabulary and language elements to facilitate communication. The study of Italian culture (i.e. food, music, art, festivals, etc.) and history will also be components of this course. Italian 11 is a continuation of Introductory Italian 11 and provides development in listening, speaking, reading and writing. Italian culture and civilization will also be components of the course.

**Joinery ACE-IT Apprenticeship
*Best, Riverside***

Students take 3 courses in Grade 12 plus Work Experience. The program includes 15 weeks of course work beginning in mid-June at BCIT. Foundation courses: Carpentry and Joinery 11 (B), Math 11 and English 11. Drafting 11 recommended.

**JumpstArt
*Gleneagle***

- an integrated, enriched Art/Humanities program offered for grade 9 and 10 students. The JumpstArt program is an excellent option for students who are passionate about art and who may plan to specialize in their senior years.

**Learning with Technology 11 Project
*Riverside***

English 11 – Learning with Technology
Socials 11 – Learning with Technology
These innovative programs provide an alternative study option for English 11 and/or Social Studies 11. Each of these courses involve the same curriculum as their regular equivalents except that technology is used to assist in the

exploration of broad curricular themes. Emphasis is on project work and exploration through research. Access to various technologies, including student laptops, is provided to ensure learning outcomes can be met. We encourage students who own a laptop computer and would like to start using it at school to consider this option. Students who do not own a laptop will be required to rent a laptop from the school. Enrollment is limited based on available space and technology. Students may enroll in both Science CO-OP (first semester) and the English and/or Social Studies Project (second semester) but this is not a requirement.

**Science CO-OP 11 – Learning with
Technology**

Chemistry 11 Co-Op
Principles of Math 11 Co-Op
Physics 11 Co-Op
Work Experience 12 Co-Op

This exciting career program will offer Grade 11 students the opportunity to enroll in Chemistry 11, Physics 11, Principles of Mathematics 11 and Work Experience 12 in the first semester of their grade 11 year (see individual course descriptions for more detail). Students will be grouped together as a “cohort” for these classes. The selected courses provide a foundation for further science studies and entrance into a university science program.

Technology will be used to assist in this exploration. Access to various technologies is provided to ensure learning outcomes can be met. We encourage students who own a laptop computer and would like to start using it at school to consider this option. Students who do not own a laptop will be required to rent one from the school. Enrollment is limited based on available space and technology. Teaching times will be adjusted so that all students in the program can go on their Work Experience after Christmas break (100 hours) and **not miss classes**. Work Experience placements will be in a science related field. Note: Science 9/10 Accelerated students who take Chemistry 11 or Physics 11 in grade 10 are not eligible for this

program. It is recommended that students have a C+ or better in Math 10 Principles & Science 10.

Learning with Technology 11 Project Centennial

- an alternative study option for English 11, Social Studies 11 and Biology 11. Enrolled in English 11 – Learning with Technology; Social Studies 11 – Learning with Technology; Biology 11 – Learning with Technology; and ICT 11 – Modular Survey.

Musical Theatre 11/12

Gleneagle, Pinetree, Port Moody, Riverside, Heritage Woods

Students will learn the basics of surging, acting and movement techniques as they relate to music theatre. The students take a leadership role in directing and producing a musical theatre performance.

Physics 12 AP Seminar

Riverside

AP Physics is designed to foster physics knowledge, problem solving ability and physics connections to other disciplines and societal issues. AP topics include; kinematics and dynamics with calculus, simple harmonic motion, angular mechanics, direct current circuits, alternating current circuits and optics.

Psychology 12 AP Seminar

Gleneagle, Riverside, Terry Fox

AP Psychology is designed to introduce students to the scientific study of human behaviour and mental processes. Students will be exposed to the psychological facts, principles, and phenomena associated with the topics of neuroscience, behaviour, sensation and perception, consciousness, learning, cognition, emotion, development, personality, disorders, and treatment. Clearly this course is a university-level Psychology preparation. Successful completion of a College Board examination will result in a placement/credit of a typical

introductory university/college course in psychology.

Recording Arts/Music Composition & Technology

Port Moody, Gleneagle, Centennial, Heritage Woods

Some of the content covered will be analog multi-track recorders, digital multi-track recorders, computer 'hard disk' recording, mixing and editing techniques, knowledge of acoustics, microphones and outboard gear such as reverb, distortion, flangers and compressor/limiters.

Rock School 10/11/12

Port Moody, Terry Fox, Gleneagle

An innovative course providing instruction on how to play in a modern pop/rock/rap/etc. group. This is for guitar players, bass guitar players, keyboard players, horn players and vocalists who already know how to play or sing but need help in putting it all together. It covers how to market yourself in the real world of music, i.e. promotion, making contracts, understanding contracts, royalties, dealing with agents and how to get a "gig".

Science Career CO-OP

Terry Fox

This program is for students interested in exploring science-related careers and doing some enrichment/application activities to extend science concepts learned in the regular curriculum. There will be opportunities for hands on experience through field trips and work experience. Students need a minimum letter grade of C+ in Science 10 in order to apply and to have demonstrated good work habits. In grade 11, students take their science and work experience courses together as a group in Semester II, so that when they do their 3-week work experience they do not miss regular class time. The grade 12 year is scheduled with the normal flexibility.

Steel Fabrication ACE-IT

Apprenticeship

Students who complete this program will be employment ready. There will be 2 intakes at BCIT starting in mid-August or February.

Foundation courses: Completion of Grade 11, Math 10 Principles or BCIT math pretest

String Orchestra 9-12

Port Moody

A credit course in orchestral instruction and performance for violin, viola, cello or double bass players. This course will explore the 'classic repertoire' and will have numerous performance opportunities. Offered in the evening so it will not take away valuable scheduling time during regular school hours, members of our community are invited to join as well.

Technology Design & Invention 11 (Industrial Design)

Pinetree, Riverside, Terry Fox

As an exciting and comprehensive program, this course involves both computer activities and project development, and relies on previously acquired design and problem solving skills. Learn to design and create wonderful devices like video games, radio-controlled machines, multi-media, battle-bots, light organs, submersibles, skyscrapers, etc. Learn more about the wonderful world of technology. This course demands a high level of interest, self-motivation and teamwork.

TRANSITION PROGRAMS

TRANSITION PROGRAMS are designed to help students explore careers while still in high school and move seamlessly to post secondary or to work. For more information, visit or contact <http://www.sd43.bc.ca/CareerPrograms> Frank Gigliotti, fgigliotti@sd43.bc.ca, or 604-937-6417.

Apprenticeship Programs					
PROGRAM	POST-SECONDARY PARTNER	PROGRAM DETAILS	CREDENTIALS	LOCATION	MINIMUM REQUIREMENTS
Automotive Service Technician	ITA	Students take 4 courses in Grade 12 plus Work Experience 12A and 12B or SSA.	Dual credit with eligibility to complete Level 1 C of Q exam in June	Terry Fox – 2 blocks a day all year long; Centennial – 4 blocks second semester	Completion of AT11 and AT12 (C+), English 12 or Communications 12, Math 11 Essentials (B), or completion of Math 11 Principles or Applications, “L” drivers license, working knowledge of computers
BAKING AND PASTRY	VCC	24 weeks with intakes in Feb. or August. Class time is 1:00pm to 7:15pm Mon to Thur. Cost is \$700	VCC, High school, and Level 1 credit with 600 hours of WBT.	VCC Downtown Campus	Foodsafe English 11
CARPENTRY	KWANTLEN	Students will take 4 courses plus 4 weeks at Kwantlen from the middle of June onwards	Dual credit and Level 1 industry credit	Terry Fox-4 blocks second semester	Math 11 Essentials and the physical ability to do the job. Carpentry 11
Construction Electrician	Camosun College	Open to grade 11 and grade 12's. Students will take 4 courses throughout the year and WEX 12A. The work experience will take place in the summer.	Dual Credit with eligibility to complete the Level 1 Exam in June.	Sept. to June at Charles Best	Principles of Math 10 or Foundations of Math 11. Once in the Program students will take Principles of Math 11 or Foundations of Math 11 and Physics 11.
Cook/Chef	Propel	Students will take a minimum of 4 courses and will be provided a Work Experience	Dual Credit and Professional Cook 1 Industry credit	Program is one semester and can be take at Centennial, Gleneagle and Riverside	Completion of Planning 10
Hairdressing	ITA	Student takes 7 courses plus Eng.12 or Comm. 12 as well as WEX 12A and WEX 12B or SSA.	Dual Credit with 1500 hours required to write the ITA exam.	10 months at Gleneagle	Completion of grade 11 preferred.
Joinery	Camosun	Students take 3 courses plus Work Experience 12A.	Dual credit with eligibility to complete Level 1.	Dr. Charles Best and Riverside	Wood 11(B), Math 11 if Essentials (B minimum) and completion of English 11 or Communications 11. Drafting 11 recommended.
PLUMBING	UA TRADE SCHOOL	Students will complete this program in 6 weeks from Mid June to the end of July	Dual Credit with eligibility to complete Level 1	UA Trade School Annacis Island	Should be in Grade 12, Math 11 Essential (C+)
STEEL FABRICATION	BCIT	23 weeks starting in February	Dual credit with eligibility to complete Level 1 and 690 hours towards their apprenticeship.	BCIT	Completion of Gr 11, Principles of Math 10 or Pre-test
Transition Programs While Attending School					
PROGRAM	POST-SECONDARY PARTNER	PROGRAM DETAILS	CREDENTIALS	LOCATION	MINIMUM REQUIREMENTS
Headstart to Art	Emily Carr	An Emily Carr Institute offers one of their foundation courses in each semester. Drawing in the first semester and Creative Processes in the second semester.	3 university credits for each course plus portfolio review	Taken at Gleneagle Tuesday night 6:00 – 9:00	Must be recommended by home school Art teacher and must meet admission requirements.
Support Across the Life Span	Douglas College	Course designed for students that are interested in careers working with disabled students and adults	Dual credit plus 3 College credit	February to Mid May David Lam Campus	Must have counselor approval
Concurrent Courses	Douglas College	University Transfer Courses beginning in September and January	3 university credits	David Lam and New West Campus	Open to Grade 12 students
Forklift, Bobcat & Scissor Lift	Dan's Forklift	Forklift is a 2 day course Bobcat and Scissor Lift is a 1 day .Courses are offered throughout the year	Industry Certification	Coquitlam	Counselor approval

<i>Transition Programs for Graduating Students</i>					
PROGRAM	POST-SECONDARY PARTNER	PROGRAM DETAILS	CREDENTIALS	LOCATION	MINIMUM REQUIREMENTS
HEALTH SCIENCES	Douglas College	Reserved Seating in Registered Nursing, Psychiatric Nursing, Dental Assisting, Dispensing Optician, Health Care Support Worker, Health Information Management	Diploma and Degree Programs	Both Campuses	Student must meet entry requirements, plus work experience, check calendar
Animal Health Technology	Douglas College	Students will find jobs working at an animal hospital or for a Vet.	Diploma program Six seats reserved	Coquitlam Campus	Biology 11 (C+), or Biology 12 (C); Chemistry 11 (C+) or Chemistry 12 (C); Grade 12 Science (C); Principles of Math 11 (C+); English 12 (B); WEX 12A (B)
Bachelor of PE	Douglas College	Student can use this course as part of the Degree program.	Dual credit for Fitness 11 and Fitness 12 credit for SPSC 1103	Both campuses	PE 12 (C+) Fitness 12 (C+)
Hospitality and Restaurant Management (HORM)	Douglas College	This program provides students with employment in the tourism industry including hotel and restaurant management.	Tourism 11/ 12 and SSA students preferential admission points. ACE-IT Level 1 Cook Training credit for HORM 1135,	David Lam Campus Two-year diploma program with transfer in a degree program at several universities	English 12 (C) and completion of Principles of Math 11

For further information on any transition program please contact:

Mr. F. Gigliotti, Transition Coordinator
SD#43 Coquitlam
604 937 6417
fgigliotti@sd43.bc.ca

WORK EXPERIENCE PROGRAMS AT A GLANCE

The Work Experience Program is intended to assist students in Grades 11 and/or 12 in exploring a *possible career choice*. Students enrolled in Work Experience *will meet graduation requirements*. The courses listed under each Work Experience Program are Strongly Recommended to an exciting work placement and generally satisfies some post secondary course requirements. Students may take ONE (1) Career Preparation Programs from the following list. Students will complete 20-25 hours of classroom based employability skills prior to a work placement of 80 hours. This fulfills the requirements for WE12.

Focus Area	Work Experience Course	Recommended Courses	Work Place Examples	Post Secondary Examples
Business/Applied Business	Business Education	2 Senior level courses from Business Education Dept.	Accounting, Advertising, Sales, Office, Computers, Management	Certificates, Diplomas, Degrees (BBA, BCOMM etc.)
Fine Arts, Design & Media	Technical Theatre	Stagecraft 11 & 12	Community Theatres, Terry Fox Theatre	Apprenticeship, Diplomas, Degrees (TTC, Dip. BFA, BA)
	Theatre Management	Stagecraft 11 & 12, Hospitality/Tourism or Drama	Terry Fox Theatre	Diplomas, Degrees (AA Degree, BBA, BTM, BFA, BA)
	Design and Media Production	2 senior level courses from the Art dept or Computer graphics 11/12 and recommendation of teacher.	Print shops, Photo Studios, Film companies, Graphic design companies	Emily Carr, BCIT, Cap College, SFU Film, UBC Film, Art Institute, Kwantlen College
Fitness and Recreation Careers	Fitness and Recreation Careers	2 senior level P.E. courses and or Athletic Leadership	Community centre, fitness facilities, gym, sporting goods store	Certificates, diplomas, degrees (B.Sc.)
Health and Human Services	Teacher Careers	English 11, Math 11	Elementary, Middle Schools	Degrees, Diploma B Ed, BA, BSc, PDP
	Early Childhood Education	Human Services/Family Management 11/12	Day Care Centres, Pre-Schools	Certificates, Diplomas, Degrees (BA, CYC)
Science And Applied Science	Science Co-op	Science 10, Biology 11, Chemistry 11, One Science 12, IDS Chemistry/Biology 12	Health Care, Laboratories, Engineering, Veterinary Clinics and many more	Technical Diplomas, Career Diplomas, Degrees (Dip. Tech, BSc)
Tourism Hospitality and Foods	Hospitality /Tourism	Hospitality Tourism 11 & 12	Sectors: Food/Beverage, Accommodation, Adventure Tourism, Attractions, Events & Conferences	Certificates, Diplomas, Degrees, Trades Qualifications
	Culinary Careers	Foods 11 & 12	Food & Beverage Sector	Certificates, Diplomas, Degrees, Trades Qualifications

WORK EXPERIENCE

Your Ticket to the 21st Century



Focus Area	Work Experience Course	Recommended Courses	Work Place Examples	Post Secondary Examples
Trades & Technology	Construction-Carpentry/Joinery	Carpentry 11A, Carpentry/Joinery 11, Carpentry Joinery 12 (Cabinet, Furniture, Residential)	Mill Work Shops, Construction Sites, Cabinet Shops	ELTT, Apprenticeships, Dip. Technology, B. Technology
	Drafting	Drafting Design 11 & 12, Drafting Design 12 (Engineering & Mechanical)	Board Work/AutoCad, Architectural Companies	ELTT, Apprenticeships, Dip. Technology, B. Technology
	General Mechanics	Automotive Technology 11 & 12 Automotive Technology 12 (Electricity & Electronics), Automotive Technology 12 (Engine & Drive Train)	Car/Motorcycle Dealerships, Independent Mechanical Services, Heavy Duty Mechanical Repair Shops	ELTT, Apprenticeships, Dip. Technology

SECONDARY SCHOOL APPRENTICESHIP PROGRAM

School District 43 (Coquitlam), in cooperation with the local office of the Ministry of Skills, Training and Labour, offer Secondary Schools Apprenticeship Programs. These programs can provide students with paid, on-the-job training, school-based skills instruction, links to the workplace and access to meaningful careers at an early age. Presently, the average age of an apprentice in B.C. is 27 years, and there is a shortage of qualified trades persons in the province and across Canada. These programs provide a

laddered entrance to structured apprenticeship training that leads to Journeyman certification and well-paid employment.

Secondary School Apprenticeship Programs differ from traditional apprenticeship programs in several ways:

- Student apprentices must be attending secondary school (grade 11 & 12) and are expected to complete graduation requirements.
- Student apprentices must complete 480 hours of paid, trade related work in

part-time/summer jobs prior to high school graduation.

- The employer must be acceptable and willing to sponsor a student apprentice.
- As an incentive for employer participation, secondary school apprentices may be paid minimum wage rather than fifty percent of regular apprenticeship program.

The District plan provides for each of the secondary schools to offer the Secondary School Apprenticeship Program.

School District No. 43 (Coquitlam)

GRADUATION PROGRAM - 80 CREDITS

Student must complete 80 credits during grade 10, 11 and 12. A minimum of 16 credits must be completed in grade 12 courses (including Language Arts 12). A total of 5 provincial exams must be written in Math 10, Science 10, Language Arts 10 and Social Studies 11 worth 20% of the final mark. Students must also write a provincial exam in their Language Arts 12 course (English 12, AP Eng or Communications 12) worth 40% of their final mark.

1. Required courses

Language Arts 10	(provincial exam)	4 credits
Language Arts 11		4 credits
Language Arts 12	(provincial exam)	4 credits
Science 10	(provincial exam)	4 credits
Science 11 or 12		4 credits
Social Studies 10		4 credits
Socials 11, Civics 11 or First Nations 12	(provincial exam)	4 credits
Mathematics 10	(provincial exam)	4 credits
Mathematics 11		4 credits
Physical Education 10		4 credits
Planning 10		4 credits
Fine Arts or Applied Skills 10, 11 or 12 course (refer to course index)		4 credits

2. Graduation Transition Plan 4 credits

3. Electives (taken at the grade 10, 11 and 12 level) 28 credits

Students must take one elective course in grade 10, or 11 or 12 that is either an applied skill or a fine arts course.

TOTAL **80 credits**

GRADUATION PROGRAM EXAMS

Grade 10 Provincial Exams (exams are worth 20% of the final mark)

- Language Arts 10 and
- One Mathematics 10 and
- Science 10

Grade 11 or 12 Provincial Exams (exams are worth 20% of the final mark)

- Social Studies 11 or
- Canadian Civics 11 or
- BC First nations 12

Grade 12 Provincial Exams (exams are worth 40% of the final mark)

- Language Arts 12 (English 12, AP Eng 12 or Communications 12)
- Language Arts 12 is a required exam worth 40% all other Grade 12 exams are optional for graduation but may be required for program entry.

PLANNING 10: 4 CREDITS

This is a required course for all grade 10 students and it is an integral part of the new Graduation Program. In this course students will begin their graduation portfolio.

GRADUATION TRANSITION PLAN

The Grad Transition Plan sets standards in key areas that are not measured by the graduation program exams. It will be started during the Planning 10 course and supported in Grade 11 and 12 with a teacher mentor. Students will complete the Grad Transition Plan in Grade 12. The three key areas include:

- Healthy Living (document and report a minimum of 150 minutes per week of physical activity)
- Work Experience (30 hours of volunteer or paid work)
- Transition Plan (5 parts: post secondary or work transition plan, financial plan, resumé, cover letter and application)

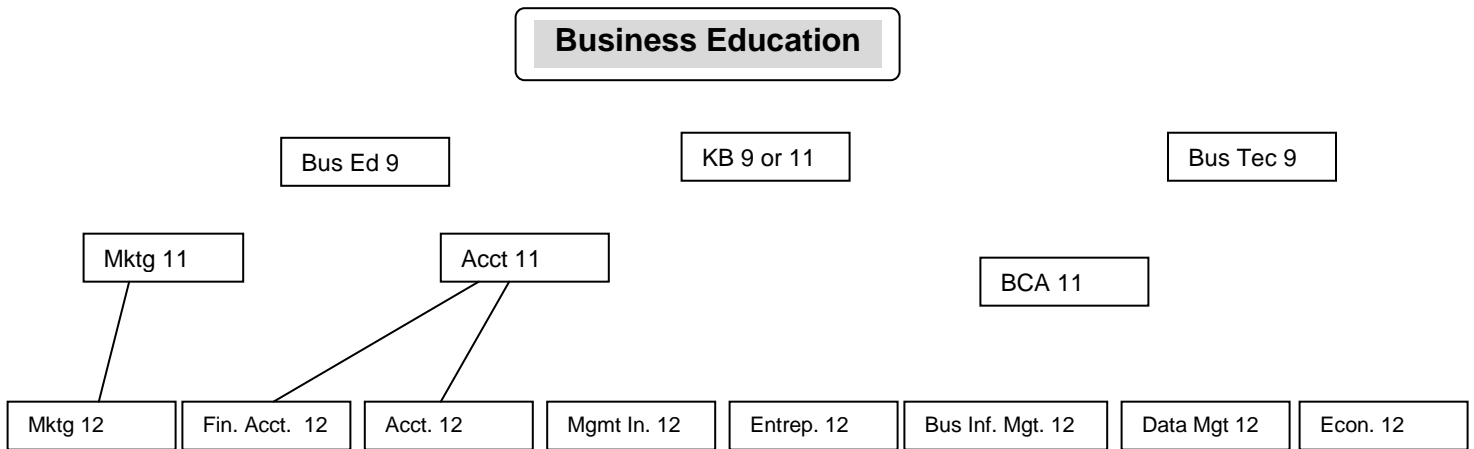
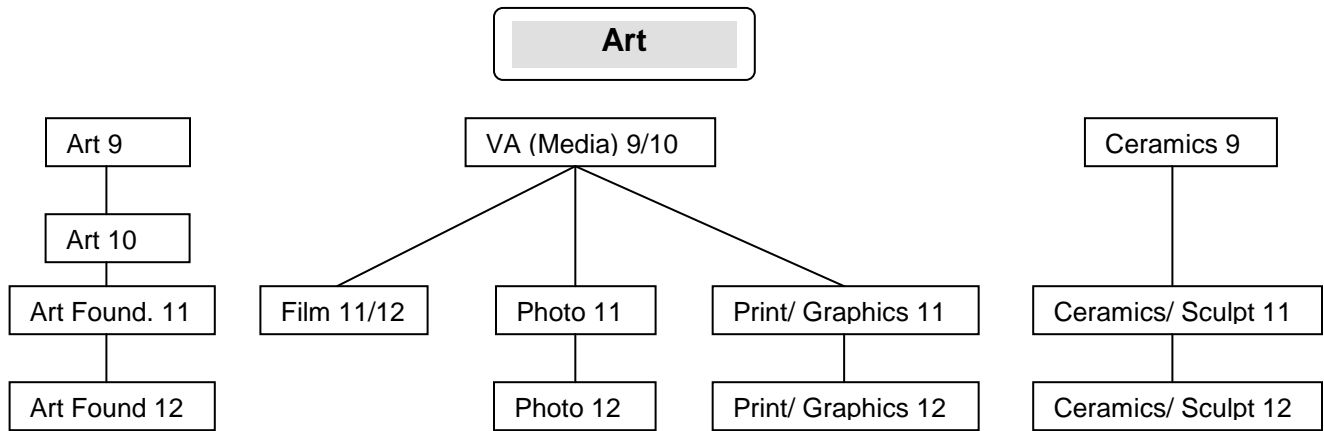

All Business Ed. 12 level courses allow for Work Experience courses (WEX 12)

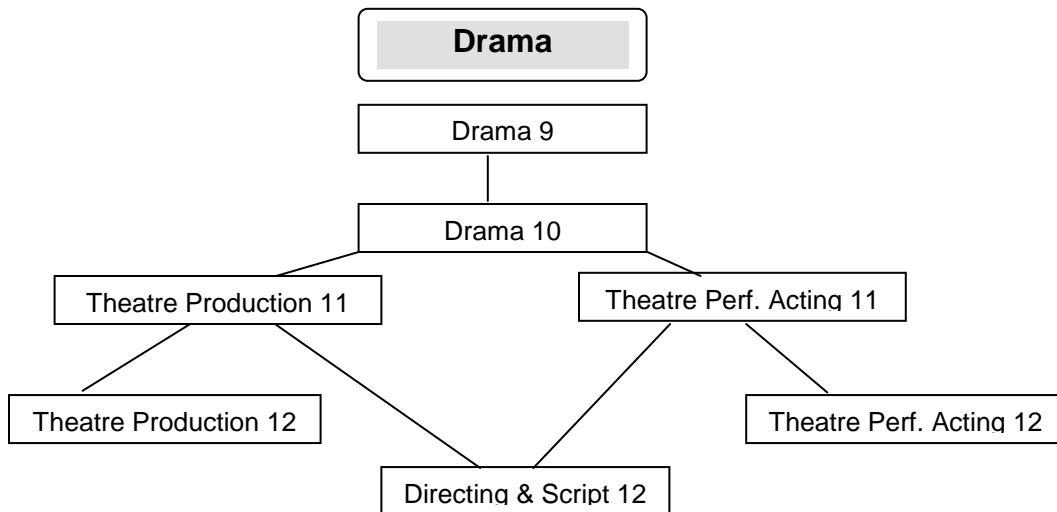

English

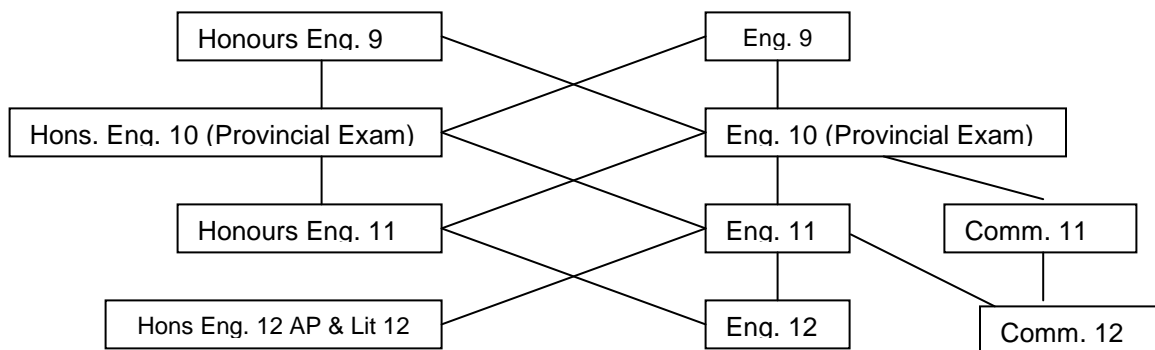

Home Economics

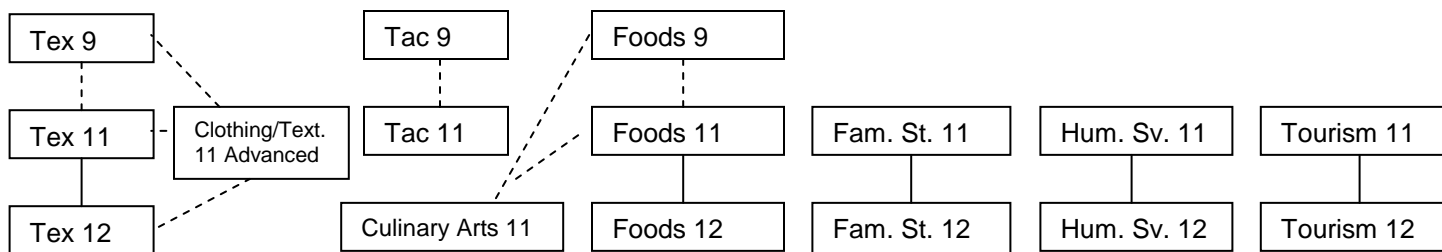

Information Technology

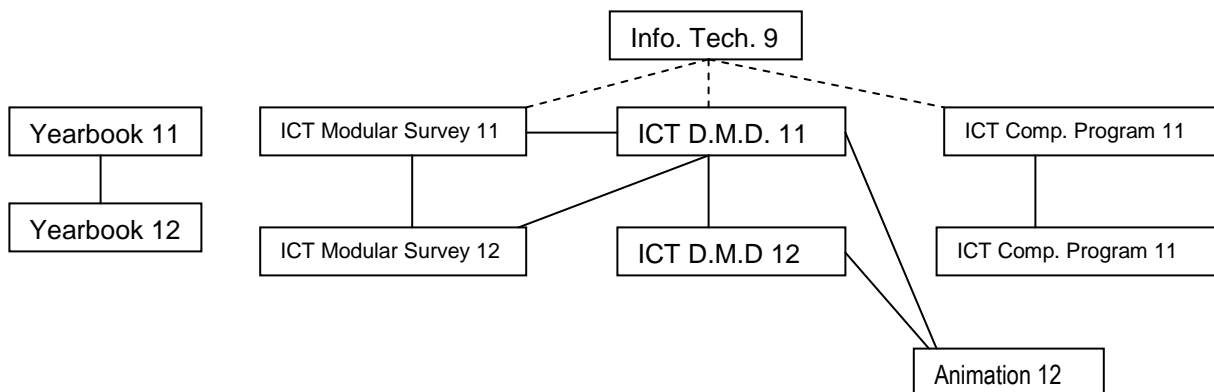

Modern Languages

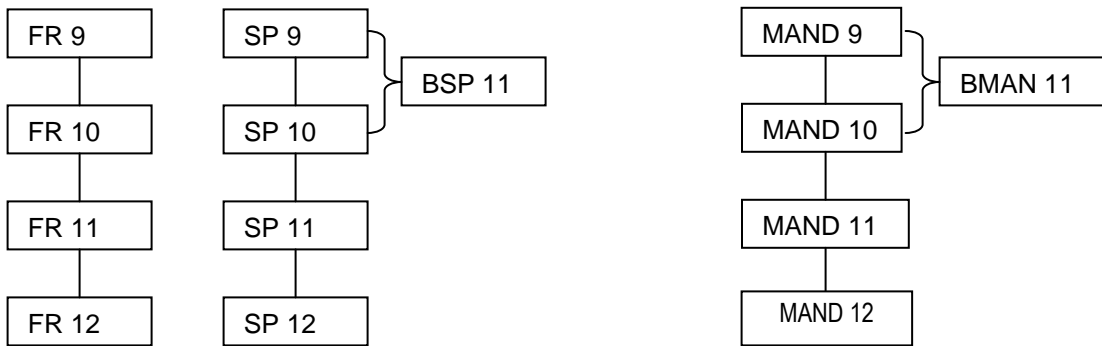

Leadership

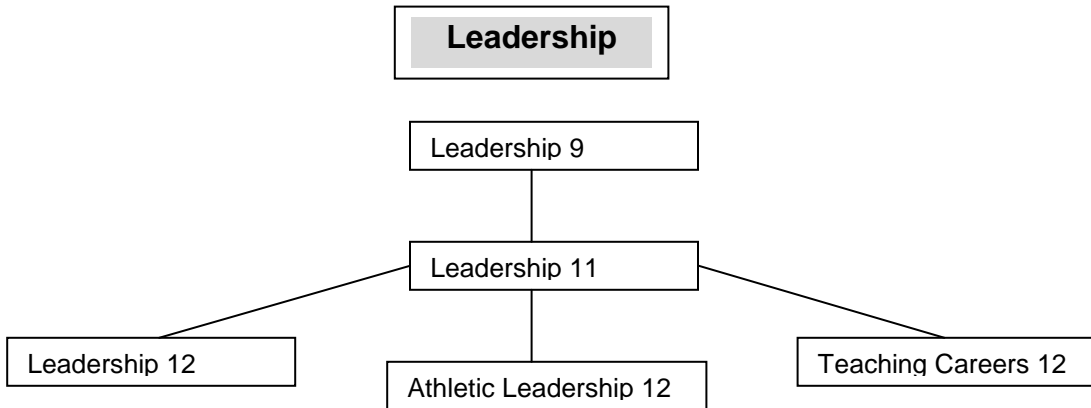

**Math Pathways (Old Program) for
2009 – 2010 Grade 10s, 11s & 12s**

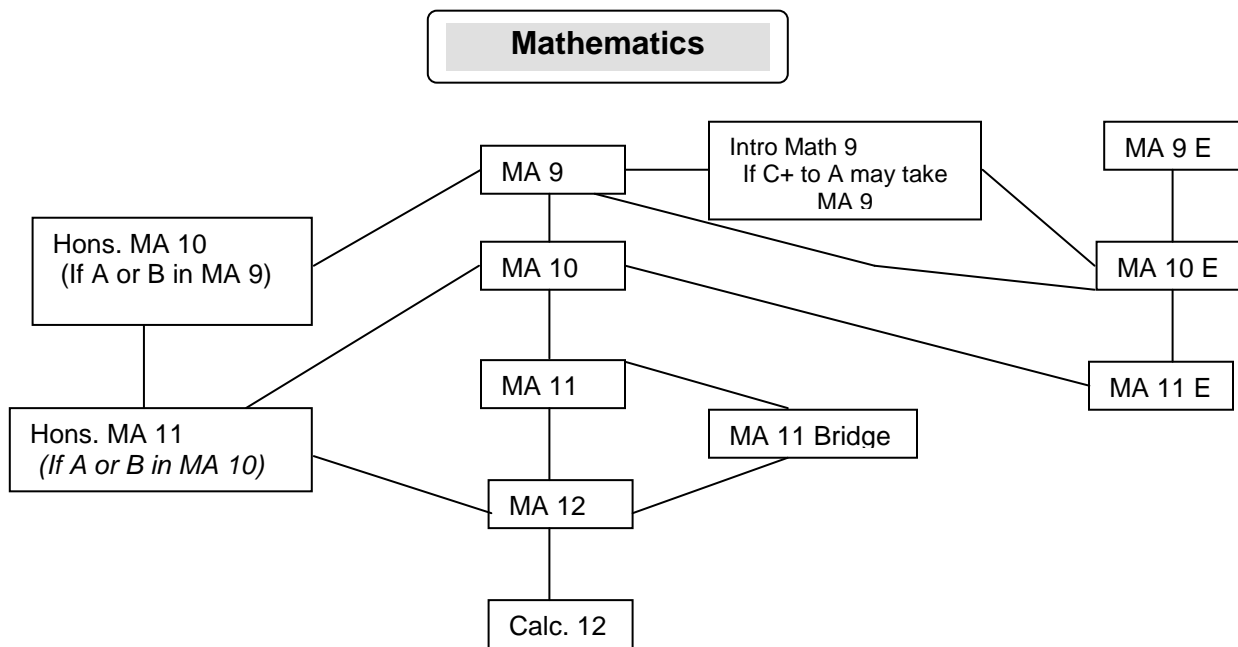

**Math Pathways (New Program) for
2009 – 2010 Grade 9s**

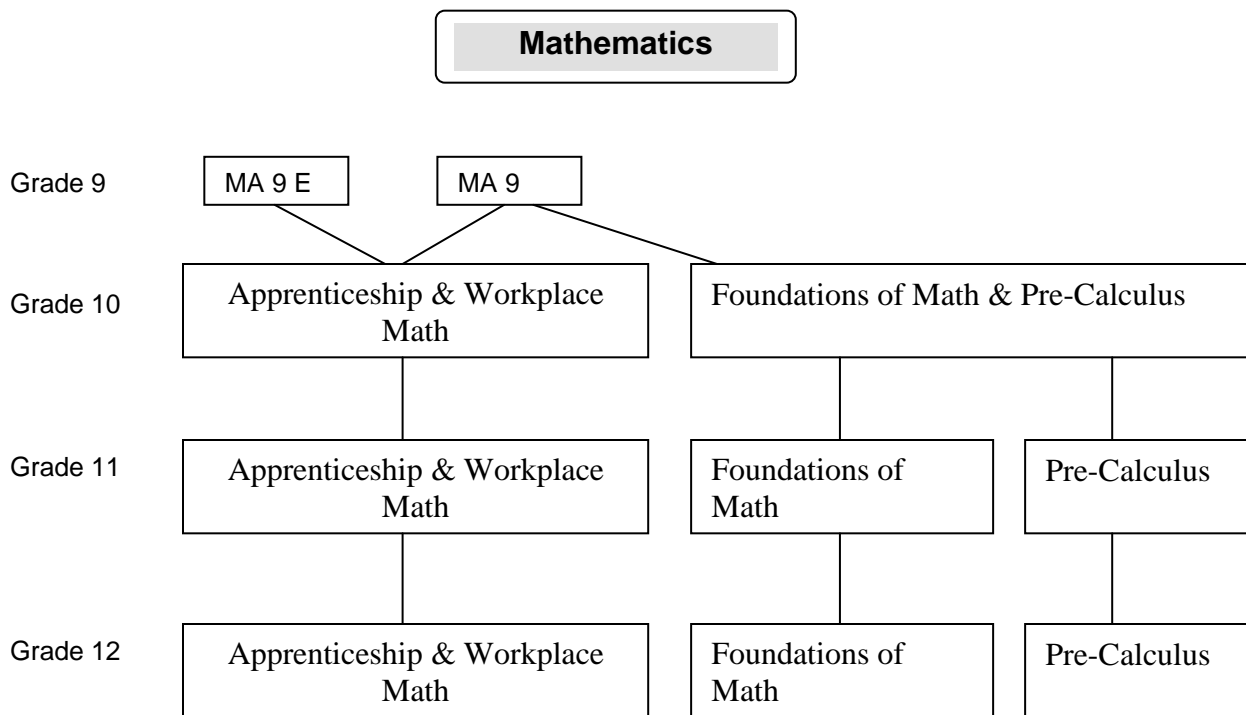

Music

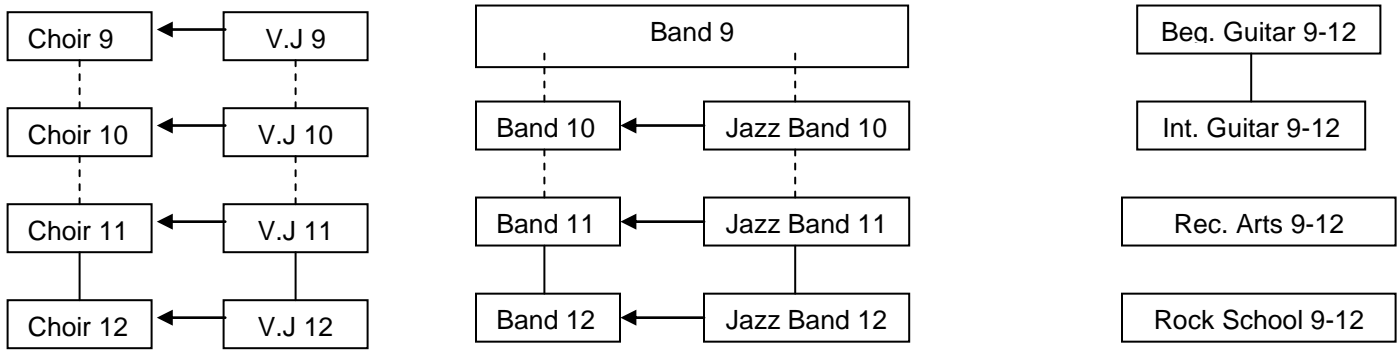

Physical Education

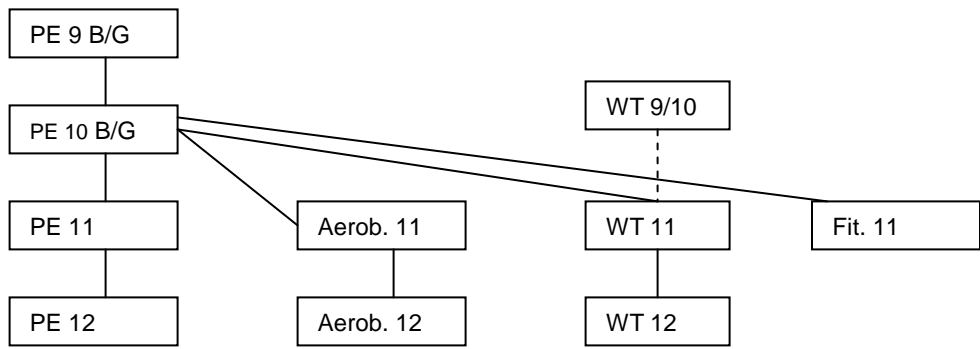

Science

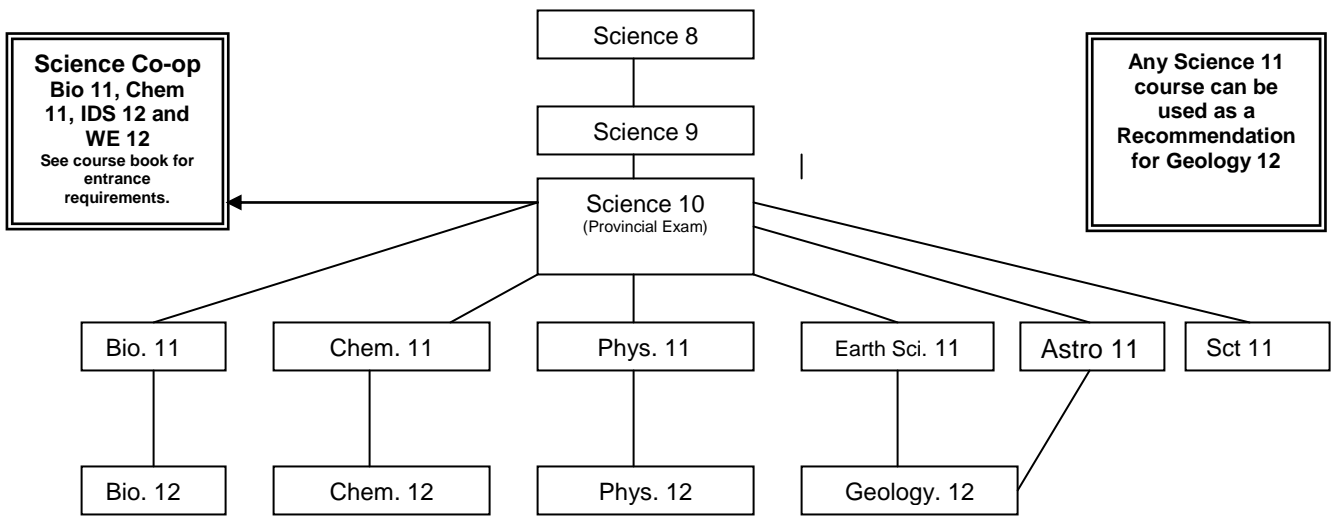

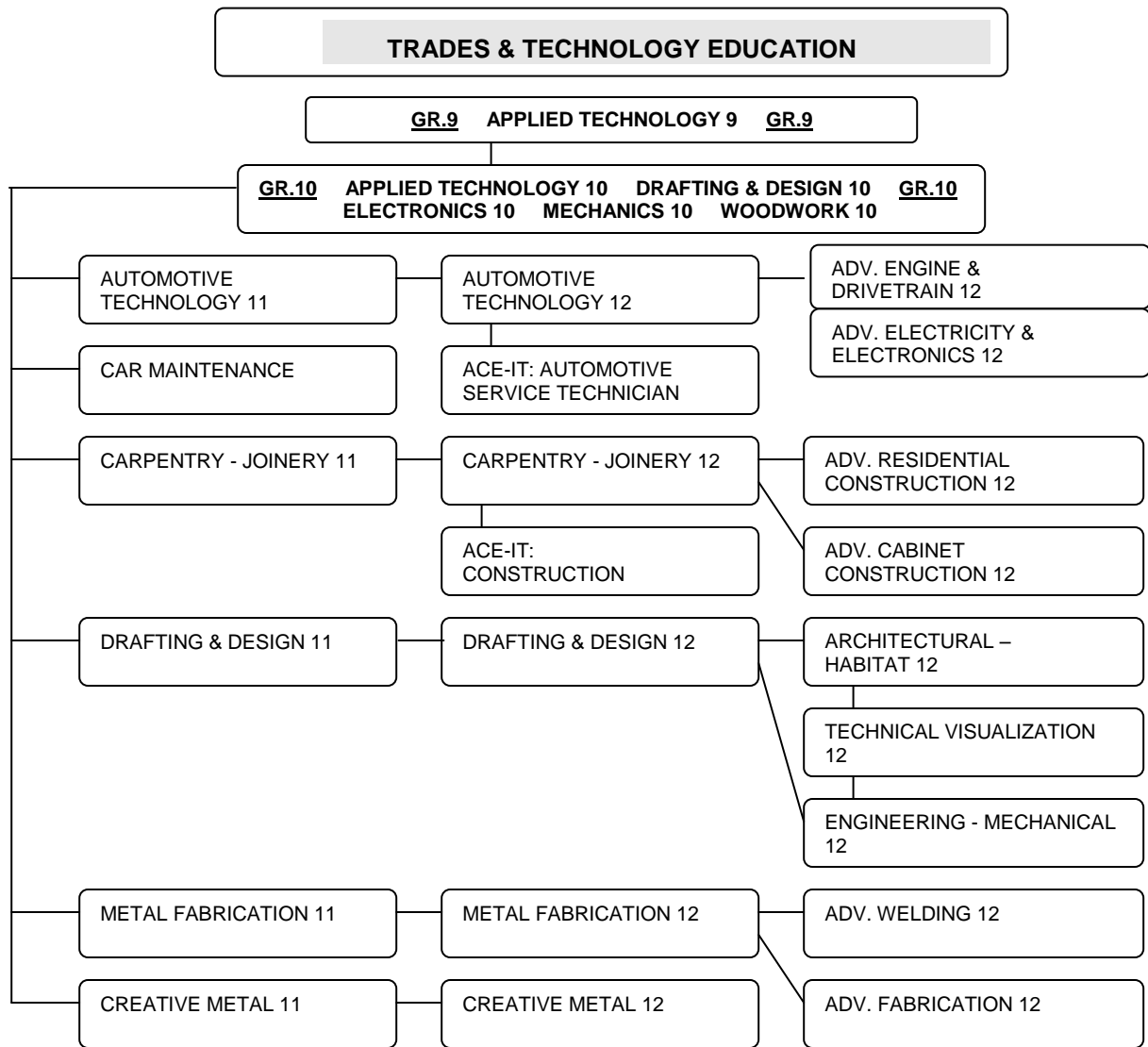
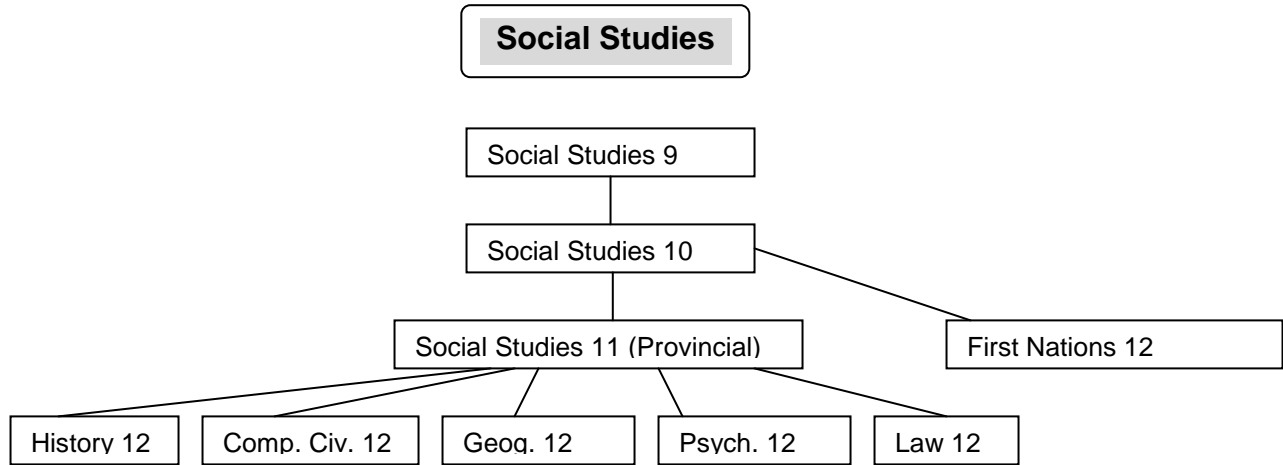

**** Additional Courses: Work Experience Trades 12 / Work Experience Automotive 12 / Work Experience Carpentry 12 ****

**ESL FLOW CHART – TERRY FOX SECONDARY
2011 – 2012**

entry dependent on age, English proficiency	Student must meet outcomes here	before	proceeding	here
entry A	Skills 1 + 2	recommending		
entry B	Humanities 9/10	recommending		English 9 Socials 9
entry C	Skills 3/4 Canadian Studies 10	recommending		English 10 Socials 10
entry D	Skills 3/4 Canadian Studies 10 Composition 11	recommending		English 11 Socials 11
entry E	Composition 11	recommending		English 12

ART

Art teaches about the human condition. Art calls upon imagination, fosters the ability to make decisions, and creates awareness that problems have multiple solutions. It also develops relational understanding, attention to nuances and students' ability to frame the world from an aesthetic perspective. Studies in Art have intellectual, creative, affective, physical, and self-developing consequences that help prepare students for the demands of the 21st century. Art is a major field of employment here in British Columbia. The Visual Arts department has a Career Preparation program in Commercial Art, and helps students prepare a portfolio with which to apply for post-secondary art studies. Take Art. It's critical.

ART 9

This is a survey course where students explore a variety of art techniques and media. 2D and 3D projects include sculpting with clay materials, drawing with conte, charcoal, pastels, inks, painting with acrylic, water colours, collage and printing methods. Projects work with humour, ceremony, realism, and self expression. Try it all. Be experimental.

MEDIA ARTS 9- 10

In this course students will get to explore art techniques that are traditionally used in the media - photography, computer graphics, printmaking, and video production. Students will pursue the topics of identity and self. This is an excellent course for creative, non-traditional students. (FNA)

CERAMICS 9

Students will use clay, plasticine, carving, media, and construction materials. The potter's wheel is always great to try, and claymation is fun to film. 3D takes creative and imaginative thinking. It's the ultimate hands-on!

VISUAL ARTS 10: GENERAL

In this survey course students explore the many functions of art – design, expression, telling a story, pursuing a viewpoint, and entertainment. A variety of materials and techniques will be presented and students

are encouraged to explore and learn many. This course offers projects that can contribute to one's portfolio for the future. Reach beyond the typical. Create what's never been before. (FNA)

ART FOUNDATIONS 11

Art 11 is a general course, as well as an opportunity that allows students to begin to specialize in the medium of their choice. Personal image development will be encouraged but is not essential to those new to the program. (FNA)

STUDIO ARTS: DRAWING & PAINTING 11

The first half of the course will focus on intensive drawing, using a variety of materials including pencil, conte, charcoal, and oil and chalk pastels. Initially, students will draw from observation and the model; later they will be taught creative drawing techniques that really work. The last half of the course will focus on water colour and acrylic painting. (FNA)

STUDIO ARTS: CERAMICS/ SCULPTURE 11

This combined ceramics and sculpture course offers students the skills and opportunity to explore different three-dimensional techniques. There will be an emphasis on ceramics. Students will learn how to hand build, throw on the wheel, and how to finish their work by glazing and firing. Students will also learn about historical and contemporary developments in sculpture and ceramics. Stone or wood carving, and plaster projects will complete the sculpture portion of this course. (FNA)

STUDIO ARTS: PRINTMAKING & GRAPHIC DESIGN 11

This is a course in commercial and graphic design; a course that future print, web, and screen designers will get a head start with. Students will design and create images that both reflect their individuality and creativity, as well as communicate messages and viewpoints through imagery. Through printmaking – silkscreen, relief and etching, along with some digital media, including Adobe Photoshop and Illustrator, students will gain an understanding of the role and

influence of media arts in society. (FNA/AS)

MEDIA ARTS 11 – 12 (FILMMAKING)

One of our province's top areas of employment is the film industry. In this course students will explore film aesthetics, and a variety of film genres, from action to documentary and the "Hollywood" format. Students will be producing several film projects, from commercials to action scenes to final "student choice", and learn skills of pre-production, such as storyboarding and scriptwriting, and post production skills such as computer editing and soundtracking. Projects will include experimental, documentary, scriptwriting, special effects editing, a project for a client, and a "student's choice" final project. You are encouraged to enter your work in one or more film festivals. (FNA)

ANIMATION 12 (BAA)

Strongly Recommended: ICT: Digital Media Development 11, Computer Graphics Animation 11 (CGA 11), Media Arts 9, Media Arts 10, or previous Computer 3D Modeling Skills.

This course is for students who are interested in 3D animation. Students will learn to model, render, and animate with a 3D animation program, Animation Master. They will learn animation techniques and processes and apply traditional animation principles to a 3D environment. Working as a team, students will research ideas, develop a storyline, transfer their ideas to storyboards, create and animate models to produce a short animated movie. Students must be able to work individually and in a team environment.

PHOTOGRAPHY 11 (BAA)

Have fun learning to take pictures like a pro. Photography gives everyone a chance to be creative. Learn all the skills necessary to take clear, well-exposed photographs, in a course suitable for beginners, as well as those with photo experience. Students will also learn to develop film, and make prints in the darkroom. Cameras are available for student use. Digital SLRs also welcome. (FNA/ASK)

ART FOUNDATIONS 12

Art students will explore in depth the mediums of drawing, painting, printmaking and sculpture. Students will learn the elements and principles of design with the aim to help them become visually literate. They will learn to read into the hidden meanings in commercial art, and the advertising media as well as in fine art work. Students will show their works in various displays and art shows. (FNA)

STUDIO ARTS: DRAWING & PAINTING 12

Senior drawing and painting students will be encouraged to explore their own personal style in no more than three art media areas. Individual instruction will be custom tailored to each student's needs and preferences. In individual and group critiques, students will analyze significant works for meaning and content, with the aim to development of visual literacy skills. (FNA)

STUDIO ARTS: CERAMICS/SCULPTURE 12

Strongly recommended: Ceramics / Sculpture 11

Students will be able to further their exploration in ceramics and sculpture. In final projects, students will be encouraged to develop a series of work reflecting their strengths, images based on their own experience and techniques of their choice. (FNA)

STUDIO ARTS: PRINTMAKING & GRAPHIC DESIGN 12

Strongly Recommended: Studio Arts: Printmaking & Graphic Design 11, or Art Foundations 11 or 12

Students will specialize in media areas of interest, and develop their skills to a high standard. They may also choose to explore career options in Media Arts, and develop skills useful in pursuing those options. Students will have the opportunity and guidance to prepare a Visual Arts portfolio suitable for submission to a post secondary art program. (FNA)

PHOTOGRAPHY 12 (BAA)

Strongly Recommended: Photography 11

Students will have an opportunity to pursue individual photography goals

through a series of free choice assignments. Students will also learn about portrait lighting, night photography, and advanced darkroom techniques. This course will prepare students to apply for post secondary professional photography programs. (FNA/ASK)

BUSINESS EDUCATION

What do most high school graduates say they are studying at post-secondary schools? Many students admit that they are studying business courses. Then why not prepare yourself by taking these courses now! You can get a head start preparing for well-paying occupations with the skills you will learn in Business Education courses. Whether you are planning on furthering your education after graduation or seeking immediate employment, Business Education is your key to success. You can also earn valuable work experience by enrolling in the Business Education Career Prep program.

COMPUTER KEYBOARDING AND SURFING THE INTERNET 9 (KB 9)

Keyboarding and computer skills are a necessity in school and in nearly every field of employment. How are your skills? Can you quickly and accurately reach all of the keys on a keyboard using all of your fingers? This is an introductory course for novice students or students who have developed bad habits from "hacking" at computers. This course will enable you to reach speeds of over 50 words per minute with amazing accuracy! The skills you learn in this course will save you hundreds of hours in the future when you prepare reports, business letters, a variety of business documents and e-mails. Students also find this course improves their concentration, spelling and English language skills. Learn valuable techniques for finding your desired information on the Internet. This course is strongly recommended by past students who rave about all of these benefits.

BUSINESS EDUCATION 9/10 (BUS ED 9/BUS ED 10)

This course covers the basic skills used in business that include marketing,

accounting, economics, money and finance, investments and international business. Computers will be used as tools to learn Internet research strategies on various topics and to prepare quality business documents and PowerPoint presentations. Numerous career opportunities in the business world will be an on-going discussion. Current business events will be emphasized. This is an excellent course for an introduction to senior-level business courses offered that students might choose later.

BUSINESS COMPUTER TECHNOLOGY 9 (BUS TECH 9)**KB 9 is recommended**

This course will give you experience and skills using computers and application programs in a business setting. Use industry standard software in a computer lab to develop skills in preparation for a business career or running your own business. Gain expertise in web page design, Internet analysis and research, presentation software and multimedia, spreadsheets and graphing, data base design, enhancing digital images and photographs, and preparation of business documents and reports. Prepare for your future and for college with this activity-based course. This course is recommended for all Grade 9 students to acquire skills for future courses and a lifetime of using technology.

PLANNING 10 (PLAN 10)

This is a mandatory course for all Grade 10 students and is required for graduation. This course will help students establish goals and help them make thoughtful decisions in many areas. Students will research post-secondary education options and possible career alternatives suited to them. Making healthy lifestyle decisions will also be highlighted during discussions on sexual health, nutrition, and substance use. Personal financial planning will also be studied with an emphasis on budgeting and preparing for post-secondary life. In addition, student graduation portfolios will begin to be prepared. Several excellent guest speakers complement topic areas.

Planning 10 – X block occurring at 6:45 – 8am.

This course is occurring at a new special time and will allow students to take Planning 10 before A block begins. This course will occur like a regular course but may allow students more freedom in choosing other electives throughout the normal school day. There needs to be at least 26 students willing to take this course in order for it to be offered.

ACCOUNTING 11 (ACCT 11)
(Open to students in Grades 10, 11, and 12)

This is an entry level accounting course that will cover the fundamentals of accounting. This is an excellent course for students who are intending to get jobs in the business world, are considering managing or owning their own business, or who will be going to college or university to take Business courses. As an introduction to accounting procedures and concepts, this course teaches students to complete the basic accounting cycle and financial statements for a small business. Students will combine written applications with computerized accounting programs and spreadsheets. This course provides hands-on practical experience with a sound theoretical base. This course does not contain any difficult Math content.

ACCOUNTING 12 (ACCT 12)
Strong Recommendation: Accounting 11 or students with an “A” or “B” in Math 11

This course provides a review of accounting concepts and introduces detailed computerized business applications. Students will use Simply Accounting software to analyze and solve accounting problems to produce computerized accounting reports for small businesses. Students learn to record and analyze business transactions using receivables, payables, inventory, payroll, bank reconciliations, project allocations, and budgeting modules for businesses. Students will learn to develop their analytical, decision-making and communication skills. Accounting 12 will benefit students pursuing a business program at the post-secondary level or

seeking immediate employment in business.

FINANCIAL ACCOUNTING 12 (FIN ACCT 12)

Strong Recommendation: Accounting 11 or students with an “A” or “B” in Math 11

This course is intended for students who wish to pursue post-secondary studies in Accounting, Business Administration, or Commerce. This course provides a general review of accounting concepts leading to the study and application of advanced accounting concepts and principles. Most of the Financial Accounting 12's content is covered in college and university courses so taking it now will help you later. Computer applications include projects using Simply Accounting, Quickbooks, and Microsoft Excel software. Note: Dual Credit at Douglas College with ACCT 110 is possible after completing this course.

COMPUTER KEYBOARDING AND SURFING THE INTERNET 11 (KB 11)
(Open to students in Grades 10, 11 or 12)

Did you miss Computer Keyboarding 9? If so, it is not too late! Keyboarding and computer skills are a necessity in school and in nearly every field of employment. How are your skills? Can you quickly and accurately reach all of the keys on a keyboard using all of your fingers? This is an introductory course for novice students or students who have developed bad habits from “hacking” at computers. This course will enable you to reach speeds of over 50 words per minute with amazing accuracy! The skills you learn in this course will save you hundreds of hours in the future when you prepare reports, business letters, a variety of business documents and e-mails. Students also find this course improves their concentration, spelling and English language skills. Learn valuable techniques for finding your desired information on the Internet. This course is strongly recommended by past students who rave about all of these benefits.

BUSINESS COMPUTER APPLICATIONS 11 (BCA 11)

KB 9 or KB 11 is recommended (Open to students in Grades 10, 11 or 12)

Looking for success in the Internet Age? Dreaming of a career in business? Use Microsoft Office (Word, Excel, Access and PowerPoint), Dream Weaver, HTML, Front Page, Photoshop and PageMaker to develop presentation and communication skills that will enhance your value to employers or for running your own business. This course will give you experience and skills using computers and application programs in a business setting. Gain expertise in web page design, Internet analysis and research, presentation software and multimedia, spreadsheets and graphing, data base design, enhancing digital images and photographs, and preparation of business documents and reports. Prepare for your future and for college with this activity-based course. This course is recommended for all students to acquire computer skills for a lifetime of using technology.

MARKETING 11 (MKTG 11)
(Open to students in Grades 10, 11 or 12)

Marketing is the most exciting aspect of the business world! It is all around us and has a tremendous influence on our daily lives. We are persuaded to buy the current fashions, technology and brand names by professional marketers.

In Marketing 11, you will have fun working on creative projects which will define the marketing mix, target markets, the psychology of consumer behaviour, market research and more. You will learn to design colourful print advertising, and develop television and radio campaigns. Using marketing strategies, you will be able to create new products of your own. We will explore market segments such as sports products, celebrity brands, teen products, retail and corporate products. Finally, you will have the opportunity to research and design your own retail business and learn all the steps you will need to create a business plan for success

Have you ever wondered about a career in business? Marketing 11 will give you the

basic knowledge of this multi-faceted world. During this course you will learn a variety of business and marketing strategies such as sales, market research, pricing, and how to be a wise consumer. You will also have the opportunity to work in the school store and create a Marketing Plan for a certain product or service. This course will give you a strong foundation for future business studies.

MARKETING 12 (MKTG 12)

Marketing 11 is highly recommended (Open to students in Grades 11 or 12)

Marketing 12 is a continuation of Marketing 11 but also focuses on the Global Marketplace. With the advances in Internet technology and the reduction of trade barriers, domestic businesses have ventured into foreign countries to expand their market share. Great opportunities are available to those who take a calculated risk!

In this course you will learn what it takes for a business to become a global player. The socio-political factors and cultural traditions of foreign countries are researched in order to develop key strategies. Buyer demands are different from country to country and marketing strategies must be designed to fulfill these demands. You will learn the functions of importing, exporting, licensing, globalization, adaptation and customization using a model of corporate global expansion.

This course is the continuation of Marketing 11. Throughout the semester you will discuss topics such as international marketing, global marketing, advertising, distribution, and marketing ethics. It will allow you to broaden your knowledge of business within our country and overseas. The group projects and individual assignment will give you the opportunity to put this information into action.

ECONOMICS 12 (ECON 12)

(Open to students in Grades 11 or 12)

Get a better understanding of how our economy works and the many economic issues that affect the way all of us live. Often major news items are related to economic topics such as unemployment,

trade, inflation, interest rates and taxes. Learn about all of these things and more! A great emphasis will be placed on government policies and current economic issues taking place nationally and internationally. This course offers market simulations, investment lessons and other economics projects on-line through the Internet. If you are interested in learning how economic events shape your life, regardless of your career interests, this course will be very helpful.

ENTREPRENEURSHIP 12 (ENTREP 12) **(Open to students in Grades 11 or 12)**

Entrepreneurship is the process of starting and operating your own business. Anyone can become an entrepreneur with the right information, knowledge and determination. Over 80% of small businesses make up our BC economy due to the innovation of entrepreneurs. That is why it is important for Terry Fox students to have the opportunity to design their own future. In this course you will be involved in the planning, organization and running of the Raven's Nest school store. As well, you will work with partners on projects that involve market research, identifying business opportunities, learning about franchises, creating brands, and finally designing a business plan for your future business.

Have you ever wondered if starting your own business might be for you? All businesses begin with the ideas of entrepreneurs, who identify and explore opportunities, do research, locate and organize resources, and then turn the ideas into reality. This course provides a practical "hands-on" opportunity to develop the entrepreneurial spirit required for starting and operating a business. Students will identify and evaluate business opportunities, assess business ideas, and develop and implement a business plan for a new venture. This course provides students with timely experiences needed for the business world. Catch the entrepreneurial spirit!

DRAMA

Drama courses at Terry Fox are exciting electives for students who want to

experience a full range of acting skills, theatre history, improvisation games, character analysis, script work and more.

DRAMA 9

This course has no Strongly Recommended and is an extension of the skills taught in Drama 8. Students are introduced to improvisation, drama, history and character study. Projects include monologue presentations, lip sync performances and scene memorization.

DRAMA 10: GENERAL

Drama 9 is highly recommended

At this level students are expected to have covered the rudimentary acting skills from Drama 9. Students will work on scene work, character analysis, movement and basic voice technique. Theatre Sport work is also presented. (FNA)

THEATRE PERFORMANCE -ACTING 11

Acting 11 is an introductory theatre course built on creative drama and theatre skills. Exploration of the discipline will focus on voice, movement, research, improvisation and character analysis. Students will study theatre history from the Greeks to Modern Day and be involved in numerous performances. (FNA)

THEATRE PERFORMANCE 12: ACTING

Acting 11 is highly recommended

Acting 12 is a continuation of Acting 11 that prepares the acting student who would like to pursue theatre at the university level or who would like a career in the arts. Drama theory will develop from styles such as Greek, Medieval, Commedia dell'Arte, naturalism and melodrama. The students will be involved in many performances. (FNA)

THEATRE PRODUCTION 11

The students will be involved with the design and construction of sets for plays and/or musicals produced by the drama department. It is recommended that students have woodwork or art experience. Specific objectives are to develop student talent in the field of scenic design, set and properties construction. (FNA/ASK)

THEATRE PRODUCTION 12: TECHNICAL THEATRE

Theatre Production 11 is highly recommended

This course is a continuation of the work and theory of Theatre Production 11. (FNA/ASK)

THEATRE PERFORMANCE: DIRECTING & SCRIPT DEVELOPMENT 12

Acting 11 highly recommended & approval of the instructor

This course is designed around the writing and producing of plays. Students will study plays using the Hodge analysis style and direct their own scenes. The Directing and Scriptwriting class will be combined with other drama classes allowing the scriptwriting student to interact and create scripts based on their various class involvement. Students need to have a passion for theatre and writing and, of course, be well organized. (FNA)

ENGLISH

Literature is placed at the centre of the English curriculum. Students of English will study literature to understand its structural features, but more importantly to gain perspective on the human condition. Students of English will learn to express themselves clearly and independently in writing and in speaking, and to be attentive and critical listeners. Students will also gain insight into some of the unique elements of the English language.

ENGLISH HONOURS PROGRAM

The English Honours Program is an enriched course of studies which prepares students for English 12, AP English 12, Literature 12, and post-secondary courses. The program covers the B.C. English Language Arts curriculum plus more challenging works of literature, including some of the classics. The full four-year program is intended to provide a good basic grounding in the mythologies, religions and philosophies that inform literature, with emphasis on the western tradition. The program also teaches varied techniques in textual analysis and criticism, writing and grammar.

ENGLISH 9

English 9 will provide students with a wide range of reading experiences. Students will study short stories, poetry, at least one novel, drama, essays, and the media. Assignments will require that students write in a variety of formats and for a variety of purposes. A study of grammar will help students express themselves clearly as they write and speak. Coherent paragraph development will also be emphasized.

HONOURS ENGLISH 9

Hon. English 9 includes the goals of English 9 with emphasis on classical and Norse mythology, poetics, poetry and stories (especially with classical allusion; themes of alienation, hope, imagination, illusion, the quest, ritual, initiation, youth, earth). A Shakespearean play and a novel will be examined. Basic sentence syntax will be stressed. First essay format: narratives (paraphrases, summaries); basic exposition; basic literary writing.

ENGLISH 10

This course will prepare students for the demands of senior level English courses. Students will be expected to write about and discuss literature in an increasingly critical and sophisticated manner. Students will develop a larger vocabulary with which to express their ideas effectively. The course includes further study of the genres presented in English 9. This course has a compulsory graduation program exam worth 20% of the final grade.

HONOURS ENGLISH 10

Hon. English 10 extends mythology and introduces philosophy and world religions – a basic survey. Other topics will include: Poetry and stories (thematically linked, focusing on religious considerations; themes of chance, the wanderer, transcendence, the good/evil dichotomy, hope, power, sacrifice, hell); a Shakespearean play; a novel; Advanced sentence syntax; Basic rhetoric; Development of expository prose; the literary essay and argumentative writing. This course has a compulsory graduation program exam worth 20% of the final grade.

ENGLISH 11

This literature-based course places emphasis on appreciation of literature and development of language and communication skills, with specific attention to the writing process and the need for increasing sophistication in students writing abilities. While students are presented with materials from a variety of genres, there is still a focus on fiction, drama, and poetry.

HONOURS ENGLISH 11

Hon. English 11 focuses on the history of the English language and literature. Other topics will include: Poetry and stories (thematically linked, focusing on political considerations; themes of power, corruption, the hero, tragedy, chaos, social conscience), Rhetorical and analytical skills as well as advanced grammar topics, Development of the argumentative essay and the literary essay.

ENGLISH 12

In English 12 students will develop a critical vocabulary with which to respond to literature, both in writing and in discussion. The principal materials studied will be short stories, poetry, novels, essays, and plays. Students should leave this course with the ability to write an insightful and well-organized essay and use descriptive, narrative and persuasive techniques effectively. This course has a compulsory graduation program exam worth 40% of the final grade.

ADVANCED PLACEMENT ENGLISH 12/ENGLISH LITERATURE 12 (FULL YEAR, DUAL CREDIT)

Students will receive credit for English 12 and for English Literature 12. Students who write the AP exam also receive an additional course credit. This course is a literature survey course intended for students wishing to write the AP English Literature Exam. Students will write the English 12 Exam in January, the AP English Literature Exam in May, and the Literature 12 Exam in June. Students may also wish to write the AP English Language Exam.

COMMUNICATIONS 11

This course is designed for students who have experienced difficulty with regular English courses due to a low skill level in reading and writing. The course focuses on practical reading and writing skills and leads to Communications 12.

COMMUNICATIONS 12

This is a practical course focusing on the use of English in everyday life. It is designed for students who would not be successful in the regular English courses. This course has a compulsory graduation program exam worth 40% of the final grade.

ENGLISH AS A SECOND LANGUAGE

The following courses are required for ESL students who are new to Canada or who need to improve their English language proficiency.

ESL BEGINNERS/LANGUAGE SKILLS 1 (non-credit)

For students whom are beginning learners of English or who are experiencing difficulties with all aspects of English listening, speaking, reading and writing.

ESL BEGINNERS/LANGUAGE SKILLS 2 (non-credit)

Provides additional support for ESL students who have passed ESL Beginners, but need further instruction in basic reading, writing and speaking skills.

E.SL HUMANITIES 9/10 (non-credit)

Humanities 9/10 is a course designed to prepare E.S.L. students for the demands of the intermediate programs in English and Social Studies.

CANADIAN STUDIES 10 (credit)

Designed to introduce students to Canadian history and geography in preparation for SS 10 and/or 11. Also acquaints students new to Canada with Canadian culture and customs. Students will be required to access additional services as outlined by the ESL teacher.

ESL SKILLS 10/11: LANGUAGE SKILLS 3/4 (non-credit)

Designed to promote English language proficiency through the study of English literature, reading, writing, speaking and listening skills.

COMPOSITION 11 (credit)

Designed to expand and consolidate senior ESL students' writing and reading skills. Students may be required to access additional services as outlined by the ESL teacher.

HOME ECONOMICS

DON'T LEAVE HOME WITHOUT IT!

Home Economics offers courses to meet the needs of *everyone*. Whether it be in Foods & Nutrition, Hospitality & Tourism, Textile Studies, Textile Arts & Crafts, Family Studies, Culinary Arts, or Child Development, students learn life long skills and explore a variety of career options. Home Economics is **THE PLACE YOU WANT TO BE!**

WEX 12A & 12B (Work Experience)

Students interested in careers in Hospitality and Tourism, Culinary Arts, Early childhood Educator, Teaching, Daycare and Fashion Merchandising are encouraged to take, along with their curricular courses, a 4 credit work experience program. WEX students participate in 30 hours of classroom instruction followed by hands on practicum experience in a community placement.

NOTE: Grade 11 courses are available to grade 10 students.

TEXTILES STUDIES 9 (INTRODUCTORY TEXTILES)

Stop shopping and start sewing! This course offers an introduction to sewing techniques through the mastery of projects appropriate to the individual. Pajamas, pants, skirts, polar fleece wear are just a few of the possible choices you will be offered in this course.

TEXTILES STUDIES 11 (INTRODUCTORY/INTERMEDIATE)

For beginner and intermediate sewers. If you love to sew or would like to learn how, Textile Studies 11 is for you. Students work at their own level to learn and review basic sewing skills as well as master

advanced, professional techniques.

Emphasis is on the creation of garments that students will enjoy and be proud to wear. (ASK)

TEXTILE STUDIES 12 (INTERMEDIATE/ADVANCED)

Strongly Recommended: Introductory Textile 9 or Textiles 11

Do you dream of creating clothing and accessories that are uniquely your own? Textile Studies 12 offers an exciting agenda as it teaches how to create clothing that is distinctly yours. Students will learn advanced sewing techniques as well as methods of redesigning and embellishing garments and accessories. (ASK)

TEXTILE ARTS AND CRAFTS 9

TAC 9 is intended to introduce a variety of crafting skills and embellishing techniques. Projects may include cross-stitch, creative writing, holiday crafts, creative ornaments, decorative painting and knitting. You do not need sewing experience, but bring lots of enthusiasm and CREATE! CREATE! CREATE! An optional \$25 fee will apply to those students who wish to create more than just the basic projects.

TEXTILE ARTS AND CRAFTS 11

Gift cards, baskets, bath salts and bombs, candles and the cutest scarecrows and bunnies are just a few of the exciting projects created in TAC 11. The projects incorporate such techniques as quilting, cross-stitching, stenciling, and decorative painting. Also taught will be the popular craft items seen in the market place. FUN is number one in this class along with enthusiasm and creativity. You will love the projects you will get to take home. Grade 10's are welcome to take this course. (FNA/ASK) An optional \$25 fee will apply to those students who wish to create more than just the basic projects.

FAMILY STUDIES 11/12 A (WEX applicable)

In an effort to better understand one's self, students will explore such topics as self concept and, personality development. Issues such as relationships, stress management, conflict resolution and lifestyle choices will be investigated

through projects, discussions, and journal writing. Students will also produce and professionally bind their own personal scrapbooks. (ASK)

FAMILY STUDIES 11/12 B (WEX applicable)

This course focuses on the development of interpersonal skills. The attention is on adult relationship issues with exploration of topics involving love, intimacy and marriage. Family planning issues and lifestyle choices will also be discussed. Students will work through various challenges that families face in today's diverse society. (ASK)

CHILD DEVELOPMENT 11 (WEX applicable)

Learn all about children from conception to birth, as infants, toddlers, preschoolers and primary students. This course is an in-depth look at the physical, emotional, social and intellectual development of each of these crucial stages. On-going visits to nearby elementary schools incorporate practical hands-on experience with in-class theory. (ASK)

HUMAN SERVICES 12C (Previously called CHILD DEVELOPMENT 11/12B) (WEX applicable)

In this course you are the teacher! You will be given the opportunity to plan and lead activities for children in a local kindergarten setting. This course is very practical: you will have opportunities to paint, create crafts, tell stories, and write your own children's book. Re-experience childhood by spending time with young children. (ASK)

TOURISM 11

Take off with tourism! Get a ticket to the fastest growing industry in B.C. Come aboard and travel throughout the province on an exciting and adventure-packed trip to your final destination - a higher level of tourism-related job skills and certification. Industry-recognized certificates include SuperHost Fundamentals and SuperHost - Serving Customers with Disabilities. Grade 10's are welcome to take this course. (ASK) There is a \$15 fee for students who wish to become certified in

each of the 2 Super Host program offered in tourism 11 (includes manual).

TOURISM 12 (WEX applicable)

Strongly Recommended: Tourism 11
The journey only began in Hospitality/Tourism 11. Domestic travel, exotic destinations and international travel is on the itinerary for Hospitality/Tourism 12. Students will also explore the business of hospitality, adventure tourism, conference and event planning, and the travel trade. Industry recognized certificates for SuperHost Japan, SuperHost Across Cultures, The Service Solution Series and Serving It Right will be available to successful students. (ASK) There is a \$15 fee for students who wish to become certified in each of the 2 Super Host program offered in tourism 12 (includes manual).

FOODS & NUTRITION 9

Wanted: A love for cooking and eating! Food is our greatest pleasure so grab your apron, don your adventuresome spirit and tempt your taste buds! This course combines basic food preparation and nutrition theory with many exciting food labs. Some all time favorite recipes gained in this course include: cinnamon apple strudel, lemon blueberry muffins, lasagna, pork fajitas and everyone's favorite chocolate brownies. Surprise yourself, friends and family with a variety of delicious treats when you sign up for this mouth-watering course. There is an optional enhancement fee of \$25 applicable to this course.

FOOD STUDIES 11 (WEX applicable)

This course is for everyone! From those who have never set foot in the kitchen to the accomplished chefs out there. With a quick review of the basics, it's time for some real taste treats. Sticky cinnamon buns, and fresh pies and pastry will test your will power. Meal planning and nutrition will provide the background to creating full course meals to tempt your palate. Bon appetit! Many food industries and post-secondary institutions require FOODSAFE Level 1 certification – also to be taught and completed in class. (ASK) \$30 *Optional fee for Food Safe certificate.*

There is an optional enhancement fee of \$25 applicable to this course.

CULINARY ARTS INTERNATIONAL 11 (WEX applicable)

Strongly Recommended: Foods & Nutrition 9/10 or Foods 11
Sharpen your knives and join the fun as you expand your international culinary repertoire. Advanced techniques will be gained here for fine food that looks good and is a pleasure to eat. Opportunities abound to plan, prepare and enjoy a variety of foods and an abundance of exotic dishes from around the world. Learn to make mouthwatering pasta from scratch, or savory perogies and samosas or spicy stir-fry's. If you like to cook and sample foods from different cultures this is the place for you! (ASK) There is an optional enhancement fee of \$25 applicable to this course.

FOOD STUDIES 12 (WEX applicable)

Strongly Recommended: Foods and Nutrition 11
The focus here is on safety, dining etiquette, preparation and presentation of foods. Advanced techniques combined with the use of a variety of different kitchen aids will be taught. Hence, it is expected that students understand the basic principles of food preparation and the value of nutrition. New and unusual foods from different cultures and catering are important aspects of this course. (ASK) There is an optional enhancement fee of \$25 applicable to this course.

INFORMATION TECHNOLOGY

Do you enjoy working and playing on computers? In Information and Technology courses students will, not only, experience a wide variety of software, but be able to develop their own multimedia rich applications. Skills learned in Information Technology courses can be applied to other subjects to create multimedia rich projects.

INFORMATION TECHNOLOGY 9

Computers are being used in almost every career area. Information and

Communication Technology 9 is a general introduction to the world of computers, which prepares students for the many different uses. This includes web design, use of the Internet and network, programming fundamentals, and areas of multimedia. Students can use the skills developed in ICT 9 to create multimedia rich projects in other subject areas. This course is taught in a modern computer lab and is open to all grade 9 students.

ICT: COMPUTER PROGRAMMING 11

Strongly Recommended: Math 10

This course is for students who like to pursue an interest in computer programming. This course will prepare students for Computer Science 12 and/or post secondary computer programming courses. We will be programming in a high level language such as JAVA, C++ or Visual Basic depending on our available resources. While creating simple programs students will learn effective problem solving skills and improve their ability to think logically. These programs will be modified and debugged by the student. The student will finish by creating a large game or education program. (AS)

ICT: COMPUTER PROGRAMMING 12

Strongly Recommended: Math 11, Computer Programming 11

This course is for students who like to pursue an interest in computer programming in University or technical college. We will be programming in a high level language such as JAVA or C++ depending on our available resources. By the end of this two-year program (CP11 and CP 12) students will know how to program: data structures, classes, streams/files, arrays, structures, functions and, graphics. (ASK)

ICT: DIGITAL MEDIA DEVELOPMENT 11 *IT 9, IT 11 or previous computer course recommended*

Digital Media Development 11 provides a practical focus that encourages students to pursue the technical side of visual media development. Students will be able to create multimedia rich projects similar to what they see on the Internet. The topics are: Desktop Digital Video; 2D Graphic Design and Publishing; 2D/3D Design and

Animation; Web Publishing. DMD 11 builds upon some of the skills learned in Information Technology 9 and ICT: Modular Survey Course 11. This course can be taken in grade 10 and applies towards graduation requirements. (ASK)

ICT: DIGITAL MEDIA DEVELOPMENT 12

Strongly Recommended: Digital Media Development 11

Digital Media Development 12 builds on the topics learned in Digital Media Development 11. This course will look at advance techniques in: Desktop Digital Video; 2D Graphic Design and Publishing; 2D/3D Design and Animation; Web Publishing. After completing this course, students will gain an understanding of careers in multimedia such as game design, web mastering, computer animation, and video effects. (ASK)

ICT: MODULAR SURVEY COURSE 11

Computers are being use in almost every career area. Information and Communication Technology 11 is a general introduction to the world of computers, and prepares students for their many different uses. This includes web design, use of the Internet and network, programming fundamentals, and areas of multimedia. This course can be taken in Grade 10 and applies towards graduation requirements as part of the new Technology graduation focus area. Modular Survey 11 is recommended for students who have not previously taken any computer courses. (ASK)

ICT: MODULAR SURVEY COURSE 12

Strongly Recommended: ICT: Modular Survey Course 11 or ICT: Digital Media Development 11

This course builds upon the topics learned in Information and Communication Technology 11. Students will be responsible for a major team project that they will design, develop, and implement. The project will demonstrate their advance skills in software development, hands-on networking (Windows and LINUX) and high-end multimedia software. By the end of this course students will have the knowledge necessary to start their future high-tech careers. (ASK)

YEARBOOK (DESKTOP PUBLISHING 11) (BAA)

Strongly Recommended: None

Want to gain some experience with computers or experience the excitement of contributing to the planning and creation of the yearbook. Get involved with every aspect of this creative work of art. From taking photos, designing layouts, meeting athletes and performers, students will learn all the skills it takes to make this years' annual a fantastic book. Students will gain the experience with meeting deadlines, organizational skills and working on a team. In addition students will learn to use specialized professional quality hardware such as scanners, colour printers and digital cameras. (FNA/ASK)

YEARBOOK 12 (BAA)

Strongly Recommended: Yearbook 11

This course is a continuation of yearbook 11 that allows the experienced 'yearbookers' to become leaders. In addition to taking photos and designing layouts the senior students will become editors and supervisors that can personally design and manage large sections of the book.

LANGUAGES

All students in all language courses are encouraged to actively participate in class in order to ensure their success. **Please refer to the Challenge process in this guide for information regarding challenging senior level Language courses.**

FRENCH

The focus in all of the French courses will be meeting the learning outcomes in the Integrated Resource Package (curriculum guide). These learning outcomes fall under the four categories of Communicating, Acquiring Information, Experiencing Creative Works, and Understanding Cultural Influences. In addition, all four-language skills, Listening, Speaking, Reading, Writing) will be addressed in each course.

FRENCH 9

Strongly Recommended: French 8
French 9 is a beginners' course. It builds on the work done in French 8 and encourages students' active participation in acquiring a basic functional level of French language. By the end of French 9, students should be able to use appropriate French expressions for a variety of spoken and written tasks (sharing opinions, giving reasons, describing, asking for detailed information, etc.) and begin to clarify time in speech and writing.

There is an optional workbook for this course.

FRENCH 10

Strongly Recommended: French 9
French 10 is an intermediate course that builds on the work done in French 9 and encourages students' active participation in increasing their functional level of French language. By the end of French 10, students should be able to use a range of useful vocabulary and expressions for a variety of spoken and written tasks (communicating needs, desires, emotions, describing events or how to do something, etc.) and link statements in past, present and future in speech and writing.

There is an optional workbook fee for this course.

FRENCH 11

Strongly Recommended: French 10
By the end of French 11, students should be able to interact in French with growing confidence in familiar situations drawn from real life. They should be able to exchange opinions on topics of interest, describe or narrate with supporting detail, discuss plans, etc. At this level, students should be refining their linking of French statements in past, present and future in speech and writing.

FRENCH 12

Strongly Recommended: French 11
This course provides students with an opportunity to develop a deeper understanding of and feeling for the idiom of the French language. By the end of French 12, students should be able to interact effectively and with some spontaneity in familiar situations drawn from real life. They should be able to give

reasons and information to support points of view on various issues, and express plans, goals and intentions for the short and long term, etc.

The course has an optional government exam worth 40% of the final mark.

MANDARIN CHINESE 9

Mandarin 9 is a first year course especially designed for students with no previous knowledge of the Chinese language. Students will develop listening, speaking, reading, and writing skills in Mandarin. In addition, students will also learn about various Chinese culture and customs. By the end of Mandarin 9, students should be able to use appropriate Mandarin expressions to perform real-life tasks, to share ideas and to acquire information.

*** This course is not suitable for a native Chinese speaker. Students who have some Chinese background will require the permission of the department.*

MANDARIN CHINESE 10

Strongly Recommended: Mandarin 9
This is a second level course of Mandarin Chinese for secondary school. Students will be expected to consolidate their knowledge of Pin Yin, simplified Chinese characters writing and the basic structure of spoken and written Chinese. Students will be exposed to Chinese culture through a variety of activities including projects, videos and field trips.

BEGINNERS' MANDARIN CHINESE 11

This beginner's course is an excellent choice for students who have not previously studied Mandarin, and who wish to enrich their language and culture experience. It prepares students for the regular Mandarin 11 course. Students will learn conversation skills, vocabulary, and basic Chinese grammar. The simplified Chinese characters will be introduced.

This intensive course incorporates both of Mandarin 9-10. As a result, it will be fast-paced. Good work habits will be required. (Grade 10 students wishing to take this course require the permission of the department.)

MANDARIN CHINESE 11

Strongly Recommended: Mandarin Chinese 10 or Beginners' Mandarin Chinese 11

Students will be encouraged to use the Chinese language in practical situations that are common to business, government, professional and social interaction. In addition, fundamental geographic, economic and social issues and the customs of China will be discussed. (Grade 10 students wishing to take this course require the permission of the department.)

MANDARIN CHINESE 12

Prerequisite: Mandarin Chinese 11
Students will further develop the four skills of listening, speaking, reading, and writing. They will become aware of and sensitive to Chinese values and customs through the study of literature and the discussion of current events.
Only available biannually.

This course will be offered in 2010/11.

SPANISH 9

Spanish 9 is a first year course providing the student with a basis for further study in the language by developing each of the language skills: listening, speaking, reading, and writing.

There is an optional workbook for this course.

SPANISH 10

Strongly Recommended: Spanish 9
Spanish 10 continues to build on the knowledge of the language and culture that students have acquired in the previous course by introducing more vocabulary and more complex grammar. The student achieves a higher level of proficiency in oral and written exercises.

BEGINNERS' SPANISH 11

This is an accelerated course (Spanish 9 and half of Spanish 10 is covered) for students who have not previously studied Spanish. It is, therefore, recommended that students be prepared to manage their time wisely throughout the semester in order to meet the demands of this course load. If you have passed Spanish 9 you cannot take this course. Grade 10 students will require permission from the

department. Students will develop a proficiency in listening, reading, speaking, and writing in Spanish.

SPANISH 11

Strongly Recommended: Spanish 10 or Beginners' Spanish 11

This course expands on the basic vocabulary and expressions taught in previous course(s). Grammar, writing and conversational skills are emphasized. Students must be willing to devote time to the mastery of these essential skills. The culture and history of the Spanish-speaking world will be further explored. *There is an optional workbook for this course.*

SPANISH 12

Strongly Recommended: Spanish 11

This course continues to expand on linguistic skills. Students will acquire a command of the key vocabulary and structures necessary for personal communication. Students will also develop an appreciation of the variety of cultures within the Spanish-speaking world.

LEADERSHIP

LEADERSHIP 9

This course offers students the chance to learn and practice leadership skills. Topics to be covered include organizational skills, communication skills, goal setting, leadership styles, event planning, motivation and group dynamics. The curriculum will vary according to the need and the abilities of the group. There are opportunities to be involved in many community and school events. Students may have the opportunity to participate in a retreat. Optional fee: for t-shirt.

LEADERSHIP 11/12

Students will be interviewed prior to be placed in this class.

Leadership 11/12 is designed to enhance your personal leadership skills and to give you the skills you need to confidently lead others. There is a practical component in the course that allows students to acquire leadership skills by getting involved in school and community events. Some pertinent topics covered in the course are:

leadership styles and behaviours, time management, event planning and implementation. Students will also learn to effectively in teams with peers of diverse backgrounds and attitudes. Teamwork skills will focus on communication, goal setting and planning, and conflict resolution. This leadership experience will help students to understand the positive impact and value that they can contribute to their community. Optional fee for t-shirt. (ASK)

ATHLETIC LEADERSHIP 12 (BAA)

Students will be interviewed prior to be placed in this class.

This course is for the sports enthusiast who would like to learn more about various aspects of leadership in a sporting environment. Some topics covered in the course are: Team Management, Basic Sport Med., Leading Intramural Activities, Building Leadership Capacity, Organization, Sports Nutrition and Event Planning. A practical component of the course will be included. If you like to work with people in the field of athletics you will have FUN in this course.

MATHEMATICS

Terry Fox's Mathematics Department offers a variety of courses designed to meet the needs of all students. It is important that students select courses that suit their interests, as well as their career and post-secondary aspirations. The Mathematics Department provides a Mathematical curriculum that helps students:

- Develop an appreciation of the role of Mathematics in everyday life
- Develop strong Mathematical skills
- Develop self-confidence and enjoyment in the study of Mathematics

The Ministry of Education requires schools to implement a curriculum shift in Mathematics that allows more options for students. Beginning in September 2009 with Mathematics 9, and each year

through to September 2012, new curriculum and teaching practices are being implemented across all SD43 secondary sites at every grade level. Students are asked to demonstrate conceptual understanding concretely, pictorially and symbolically using the mathematical processes of communicating, connecting, mental math and estimation, problem-solving, reasoning, technology and visualization. The graphic below illustrates Ministry of Education required course options that will be offered beginning with Apprenticeship and Workplace Mathematics 10 and Foundations of Mathematics and Pre-Calculus 10 in September 2010.

MATHEMATICS 9

This course is designed to consolidate and extend topics introduced in the middle school years. Topics include operations with rational numbers, square roots and exponents, polynomials and algebra, linear relations, geometry and statistics. At the end of this course, students will be prepared for Foundations of Mathematics and Pre-Calculus 10 OR Apprenticeship and Workplace Mathematics 10.

ESSENTIALS OF MATHEMATICS 9

This course is for students who have not met the passing requirements for Principles of Mathematics 8. The course emphasizes basic mathematical life skills.

APPRENTICESHIP & WORKPLACE MATH 10

This option is designed to provide students with the Mathematical understanding and critical-thinking skills identified for entry into the majority of trades and for direct entry into the work force. Topics include understanding and applying the metric and imperial systems to the measurement of 2-D and 3-D objects, geometry and trigonometry, and the fundamentals of income, spending and debt. All topics are taught within a framework of problem-solving. This course has a mandatory graduation program exam. At the end of this course, students are prepared for Apprenticeship and Workplace 11. Students may also choose one of the other Mathematics 10 or 11 course options pending departmental consultation.

FOUNDATIONS OF MATHEMATICS & PRE-CALCULUS 10

This option is designed to provide students with the Mathematical understanding and critical-thinking skills identified for post-secondary academic studies at colleges and universities. Topics include surface area and volume of 3-D objects, applying trigonometric ratios to right triangles, irrational numbers, powers involving integral and rational exponents, polynomials, and coordinate geometry with linear relations, systems of linear equations, and function notation. At the end of this course, students are prepared for either Foundations of Mathematics 11 OR Pre-Calculus 11.

APPRENTICESHIP & WORKPLACE MATHEMATICS 11

This course is designed to provide students with the mathematical understandings and critical-thinking skills identified for entry into the majority of trades and for direct entry into the work force. The course will include topics in Measurement, Geometry, Finance, Algebra and Statistics.

FOUNDATIONS OF MATHEMATICS 11

This course is designed to provide students with the mathematical understandings and critical-thinking skills identified for post-secondary studies in programs that do not require the study of theoretical calculus. This might include the Humanities, Fine Arts, some Trades and Technical programs. The course will include such topics as Measurement, Relations and Functions, Geometry, Statistics and Logical Reasoning.

PRE-CALCULUS 11

This course is designed to provide students with the mathematical understandings and critical-thinking skills identified for entry into postsecondary programs that require the study of theoretical calculus. This might include Mathematics, Sciences, Engineering and Commerce. The course will include Absolute Value, Radical and Rational Equations, Quadratic Functions, Arithmetic and Geometric Sequences and Series and Trigonometry.

Programming Notes:

Students may choose to take more than one of these courses. It is important that students and their parents work with counselors and Math teachers to ensure courses selected will allow for the greatest success and meet both general entrance requirements and specific department requirements for post secondary plans. It is the responsibility of the student to fully research university, college and technical school requirements.

The new curriculum for Mathematics 12 will begin in the 2012-2013 school year: Apprenticeship and Workplace Math 12, Foundations of Math 12 and Pre-Calculus 12.

PRINCIPLES OF MATHEMATICS 12

Topics in this course include: transformations, trigonometric functions, equations and applications, trigonometric identities, exponential and logarithmic functions and their application, permutations and combinations and probability. Independent problem-solving is stressed throughout the course. This course has an optional graduation program exam worth 40% of the final mark.

CALCULUS 12

Prerequisite: Principles of Mathematics 11
This course is very valuable for those students who have excellent mathematical ability and intend to study mathematics and economics, engineering or science. The main topics covered are: properties of functions, analytic geometry, limits, derivatives, integrals and their application. *No government provincial examinations are offered in this course.*

MUSIC

The music department at Terry Fox firmly believes that participation in the arts is essential for the development of the whole person. At Terry Fox we offer students the opportunity to participate in a wide variety of music courses at every level of ability.

Besides the obvious enjoyment that comes from participating in music, there is a growing body of evidence leading to the conclusion that involvement in music leads students to greater success in other areas of learning. Through music, students:

- gain a sense of discipline, self-esteem, and pride of accomplishment
- are encouraged to be active participants in their work rather than just observers
- become better at problem solving. They will be self-critical and also learn to self-correct
- learn teamwork, co-operation, and leadership skills
- gain confidence, self-expression, and communication skills
- gain enhanced memory skills and concentration
- form bonds of friendship and memories that will last a lifetime

Perhaps most importantly, it has been shown in several studies that there is an unmistakable causal link between music and spatial intelligence (the ability to perceive the visual world accurately, to form mental images of visual objects, and to recognize variations of objects). These spatial reasoning skills are essential to the studies of math, science and engineering, and many colleges and universities give weight to people who have studied classical and jazz music when reviewing applications for entrance, scholarship, or bursaries.

CONCERT BAND COURSES

Concert band is perfect for anyone wanting to learn to play a woodwind, brass, string, or percussion instrument. The emphasis is on developing playing skills and musicianship. Students will perform in several concerts and festivals each year and will be able to participate in any scheduled tours or retreats. In past years, the band has travelled to Alberta, Washington, Idaho, Oregon, California, New York, Cuba, and within BC. All concert band courses are scheduled during the regular timetable. Beginner band students are welcome at all grade levels.

BAND 9:

For students in gr. 9. Band 9 will run as a regular semester course in first term.

Students in Band 9 will learn and experience music by playing in both a large Concert Band and a Jazz Combo setting.

MUSIC 10: CONCERT BAND

For students in gr.10 (FNA)

INSTRUMENTAL MUSIC 11: BAND

For students in gr. 11 (FNA)

INSTRUMENTAL MUSIC 12: BAND

For students in gr. 12

JAZZ BAND COURSES

NOTE: Students in Jazz Band 10/11/12 should also be enrolled in a Concert Band class. Exceptions to the Concert Band co-requisite for Jazz Band may be made with permission from Mr. Cho.

This course is for students who are interested in exploring jazz music through playing and learning instrumental music. Traditional, as well as non-traditional jazz instruments are accommodated. Interpretation, technique, and improvisation will be covered. Jazz Band 10/11/12 runs within the timetable on alternate days with Concert Band 10/11/12.

JAZZ BAND 10 (FNA)

Co-requisite: Band 10

JAZZ BAND 11 (FNA)

Co-requisite: Band 11

JAZZ BAND 12 (FNA)

Co-requisite: Band 12.

CHOIR COURSES

Everyone who likes to sing is welcome to join the Concert Choir. No prior musical experience is necessary. Students will learn a wide variety of music as they rehearse repertoire and prepare for performances. Vocal techniques, performance skills and music reading will be taught. The choirs will present several concerts each year and will have the opportunity to participate in any tours or retreats that the department undertakes.

NOTE: Since Concert Choir is scheduled into Block E, it may be taken in addition to a 8 course load.

CONCERT CHOIR 9

For grade 9 students.

CONCERT CHOIR 10 (FNA)

For grade 10 students.

CONCERT CHOIR 11 (FNA)

For grade 11 students.

CONCERT CHOIR 12 (FNA)

For grade 12 students.

VOCAL JAZZ COURSES

These courses are intended for singers interested in learning vocal jazz and popular music. No prior musical experience is necessary. In addition to vocal techniques, performance skills, and music reading, vocal jazz courses will include microphone technique and scat singing (improvisation technique for vocalists). Concert Choir is a co-requisite for all Vocal Jazz courses, as material covered in Concert Choir will act as a skill basis for activities done in Vocal Jazz classes. **Vocal Jazz may be taken in addition to a full course load.**

VOCAL JAZZ 9

For grade 9 students.

Co-requisite: Choir 9

VOCAL JAZZ 10 (FNA)

For grade 10 students.

Co-requisite: Choir 10

VOCAL JAZZ 11 (FNA)

For grade 11 students.

Co-requisite: Choir 11

VOCAL JAZZ 12 (FNA)

For Gr. 12 students.

Co-requisite: Choir 12

GUITAR COURSES

BEGINNING GUITAR 9-12

This course is designed for those with little or no previous experience on the guitar. Students begin by learning the basic chords and how to read guitar music. In addition to learning many songs, students will learn strumming, picking, and classical techniques. A rock guitar unit covers rock strums, power chords, barre chords, and some lead guitar techniques. The school provides guitars and music for this course

NOTE: If you already read music and play guitar at a fairly advanced level you MAY be able to challenge BEGINNING GUITAR and go immediately to INTERMEDIATE GUITAR. Written permission from the instructor is required.

INTERMEDIATE

GUITAR 9-12

Strongly Recommended: Beginning Guitar or permission of the instructor.

This course is designed for students who have successfully completed BEGINNING GUITAR or equivalent. (See note above) The emphasis will be on continuing to develop note reading, chording, and accompaniment skills. Students will receive individualized instruction for part of the term and will be able to choose an area of concentration, eg. classical guitar, rock guitar, jazz guitar, etc. The school provides guitars and music for this course. (FNA)

DRUMMING 11: WORLD BEAT (BAA)

This course gives students the opportunity to explore hand drumming and world percussion through performance, practice, and composition. Drums and percussion instruments will be provided for each student. Students will work with the musical elements of form, dynamics, movement and rhythmic design for various drumming and percussion styles from around the world. Some elements of West African Drumming, South American Rhumba, the Blue Man Group, and Stomp will be created. The ability to read music is not necessary. Evaluation in this course will be based on daily participation, skill progress, projects and final performances. (FA)

ROCK SCHOOL 9

(CONTEMPORARY MUSIC 9)

Students should have some beginner music skills, but it is not absolutely necessary...All students are encouraged to join. Beginner students will have the opportunity to learn their instruments during the course and will not be required to perform at the final show if they are not yet performance ready

This course is designed to create a learning environment for beginner/intermediate musicians who wish to perform in a rock band format. Students

will receive basic instruction in how to play their instruments. They will also learn how to organize and rehearse a contemporary music ensemble. Students will be able to choose their instrument and style of music. Students will also be taught the following: history of popular music, operating and maintaining basic equipment, performance techniques and audience interaction, recording opportunities, developing promotional materials and understanding the music business. Opportunities to perform will be made available, **but performance at the year-end concert is not mandatory in Grade 9.**

ROCK SCHOOL 10

(CONTEMPORARY MUSIC 10 BAA)

Students should have mastery of beginner level skills on instrument or voice.

However, ALL Students are invited to join rock school for the first time in order to develop their musical skills.

A continuation of Contemporary Music 9, this course is designed to create a learning environment where students who are already able to play their instrument(s) will receive instruction in how to organize and rehearse a rock band contemporary music ensemble. Students should have enough ability to play through a simple song to a CD at tempo. ***However, beginners are encouraged to join in order to develop their music skills for the first time.**

Students will **develop the ability** to perform at an intermediate level and have the ability to have intermediate knowledge of equipment set up and maintenance. Opportunities to perform will be made available. **Beginner students will have the opportunity to learn their instruments during the course and will not be required to perform at the final show if they are not yet performance ready. These students will receive a adapted grade.**

ROCK SCHOOL 11

(CONTEMPORARY MUSIC 11 BAA)

Students should have mastery of beginner level skills on instrument or voice.

However, ALL Students are invited to join rock school for the first time in order to develop their musical skills.

A continuation of Contemporary Music 10, this course is designed to create a learning

environment for advanced musicians who will receive instruction in how to organize and rehearse a professional rock band contemporary music ensemble. Students should have enough ability to play through a simple song to a CD at tempo.

Experienced students will be expected to perform a full set of contemporary music. Opportunities to perform will be made available. **Beginner students will have the opportunity to learn their instruments during the course and will not be required to perform at the final show if they are not yet performance ready. These students will receive an adapted grade.**

(FNA)

ROCK SCHOOL 12

(CONTEMPORARY MUSIC 12 BAA)

Students should have mastery of beginner level skills on instrument or voice.

However, ALL Students are invited to join rock school for the first time in order to develop their musical skills.

This course is designed to continue a more in depth study of the concepts taught in Contemporary Music 11 and apply them to performing complex arrangements.

Students **should** have enough ability to play through a simple song to a CD at tempo. ***However, beginners are encouraged to join in order to develop their music skills for the first time.**

Beginner students will have the opportunity to learn their instruments during the course and will not be required to perform at the final show if they are not yet performance ready. These students will receive an adapted grade. Different approaches to arranging contemporary (rock) music will be explored. Students will be instructed in methods of communicating contemporary arrangements to a rock band musical ensemble in order to rehearse and perform them. Students will be instructed on copyright law and registering with SOCAN as well as reviewing other essential information regarding the music business. (FNA)

RECORDING ARTS AND SCIENCES 9 (Beginner Level)

Students should have some beginner music skills, but it is not absolutely

necessary. All students are encouraged to join.

This is an introductory course designed for students who want to learn how to digitally record music. Students will get hands on instruction in basic modern recording techniques, which are essential to the professional composer/recording artist. A CD featuring students' recordings will be produced at the end of each year.

RECORDING ARTS AND SCIENCES 10 (BAA)

Students should have some beginner music skills, but it is not absolutely necessary. All students are encouraged to join.

This is an intermediate course designed for students who want to learn how to digitally record music. Students will get hands on instruction in multi-track recording techniques, which are essential to the professional composer/recording artist. A CD featuring students' recordings will be produced at the end of each year. Students who register for this course should be able to play at least one musical instrument and/or be able to sing, but this is not absolutely necessary as the focus of this course is on audio engineering and not musical performance. (FNA/ASK)

RECORDING ARTS AND SCIENCES 11 (BAA)

Students should have some beginner music skills, but it is not absolutely necessary. All students are encouraged to join.

This is an advanced course designed for students who want to learn how to digitally record music. Students will get hands on instruction in multi-track recording and digital editing techniques, which are essential to the professional composer/recording artist. A CD featuring students' recordings will be produced at the end of each year. Students who register for this course should be able to play at least one musical instrument and/or be able to sing, but this is not absolutely necessary as the focus of this course is on audio engineering and not musical performance. (FNA/ASK)

RECORDING ARTS AND SCIENCES 12 (BAA)

Students should have some beginner music skills, but it is not absolutely necessary...All students are encouraged to join.

This is an advanced course designed for students who want to learn how to digitally record music. Students will get hands on instruction in multi-track recording, digital editing and mastering techniques, which are essential to the professional composer/recording artist. A CD featuring students' recordings will be produced at the end of each year. Students who register for this course should be able to play at least one musical instrument and/or be able to sing, but this is not absolutely necessary as the focus of this course is on audio engineering and not musical performance. (FNA/ASK)

PHYSICAL EDUCATION

PHYSICAL EDUCATION 9

This course will include an introduction and exposure to a wide variety of team, partner and individual activities with emphasis on basic skill development, fitness and sportsmanship. Activities may include volleyball, football, lacrosse, wrestling, minor games, basketball, dance, ultimate Frisbee, badminton, ball hockey, table tennis and softball.

PHYSICAL EDUCATION 10

This course is a continuation of the PE 9 course but more advanced skills and game strategies will be taught. In addition to the PE 9 curriculum there may also be the opportunity for instruction in rugby, tennis, and CPR certification.

PHYSICAL EDUCATION 11

Strongly Recommended: P.E. 10

This course is designed for Grade 11 or 12 students who enjoy team sports and individual activities in a variety of sport settings. Students will participate in a variety of school-based and optional community-based activities including: bowling, golf, volleyball, softball, ball hockey, basketball, touch football, ultimate Frisbee, tennis, table tennis, soccer,

dodge ball, weight training, swimming and handball. Weekly cardiovascular workouts and runs are important components of this course.

Optional \$50 Course Enhancement Fee to fund community activities.

PHYSICAL EDUCATION 12

Strongly Recommended: Physical Education 11

This course is an extension of the PE 11 course and is designed for Grade 12 students who enjoy team sports and individual activities in a variety of sport settings. Students will participate in a variety of school-based and optional community-based activities including: bowling, golf, volleyball, softball, ball hockey, basketball, touch football, ultimate Frisbee, tennis, table tennis, soccer, dodge ball, weight training, swimming and handball. Weekly cardiovascular workouts and runs are important components of this course.

Optional \$50 Course Enhancement Fee to fund community activities.

FITNESS 11 (AEROBICS) BAA

This co-educational elective course is designed for students who desire to increase cardiovascular and muscle fitness. Students will engage in intense cardiovascular classes, inclusive of aerobics, stability ball workouts, circuits as well as fitness knowledge theory (1 class per week). Students enrolled in the course will have the option to become certified in Fitness Knowledge (the base course needed for becoming an aerobics instructor, water fit instructor or weight trainer). Only those students who wish to be challenged should consider taking this course.

Optional certification & Course Enhancement fee.

FITNESS 11 (FIT FOR LIFE) BAA

In this coeducational course students will experience a wide variety of fitness and recreation activities such as power walking, jogging, strength training with weights, balls and bands, and team sports. Students will spend some classroom room time designing and implementing plans for balanced, healthy living including exercise, nutrition, stress management and well being, rest and work. They will design

specific personal fitness programs using the fitness components, principles of training and energy system usage. Concepts in fitness and nutrition will enable students to keep a detailed log book of their training and diet. Students will develop fitness programs that can be adapted to their changing fitness goals and personal fitness level. The ultimate goal is to enable students to maintain a fitness program for their entire life in a manner that is active, informative, and enjoyable.

FITNESS 12 (AEROBICS) BAA

Strongly Recommended: Fitness 11 Aerobics

This co-educational elective course is a continuation of Fitness 11 Aerobics with an emphasis on increasing cardiovascular and muscle fitness. As in Aerobics 11 students will engage in challenging fitness classes. Students enrolled in this course have the option to be certified in the CFES (Canadian Fitness Education Services) Aerobics instructor course. Those students who choose to be certified will learn about instructor teaching skills, program planning, and the components of an aerobics class and safety considerations.

Optional certification & Course Enhancement fee.

WEIGHT TRAINING 9

This co-educational course provides the opportunity for students to actively develop personal fitness. The objective of this elective program will be to utilize a variety of training methods to achieve improved levels of fitness. Weight training will be the foundation of this course and should be of interest to students with or without previous weight training experience since basic techniques and safety will be fundamental to the program.

Optional \$8 workbook fee.

WEIGHT TRAINING 10

This co-educational course provides the opportunity for students to actively develop personal fitness. The objective of this elective program will be to utilize a variety of training methods to achieve improved levels of fitness. Weight training will be the foundation of this course and should

be of interest to students with or without previous weight training experience since basic techniques and safety will be fundamental to the program. Optional \$8 workbook fee.

FITNESS 11 (WEIGHT TRAINING) BAA

This co-educational elective course is offered as a continuation of the program developed in the Weight Training 9/10 option. The course emphasis will be on developing and maintaining personal fitness. Weight training and selected exercise techniques will provide the basis for this course. Circuit training, split routines, pyramid training and developing your own program are emphasized. This course is highly recommended for all student athletes.

Optional \$8 workbook fee.

FITNESS 12 (WEIGHT TRAINING) BAA

This co-educational elective course is offered as a continuation of the program developed in the Weight Training 11 course. The course emphasis will be on developing and maintaining personal fitness. Weight training and selected exercise techniques will provide the basis for this course. The BFS (Bigger, Faster, Stronger) program is emphasized. This course is highly recommended for all student athletes. ~~(AS)~~

Optional \$8 workbook fee.

FITNESS 11A (AGILITY TRAINING) BAA

This course is designed for athletes who wish to develop sport specific fitness and skills. Students will focus on a wide variety of advanced conditioning programs such as plyometrics, interval training, running, and weight training as they relate to football. Specific physical components of the course will include speed, agility, weight training and quickness. Special emphasis will be placed on developing individual skill development programs that best meet the student's needs. This course is open to grade 10, 11 and 12 student athletes.

Optional \$8 workbook fee.

FITNESS 11B (AGILITY TRAINING) BAA

This course is designed for athletes who wish to develop sport specific fitness and skills. Students will focus on a wide

variety of advanced conditioning programs such as plyometrics, interval training, running, and weight training as they relate to basketball. Specific physical components of the course will include speed, agility, weight training and quickness. Special emphasis will be placed on developing individual skill development programs that best meet the student's needs. This course is open to grade 10, 11 and 12 student athletes and will be offered on a linear schedule from 6:45am to 7:30am.

SCIENCE

SCIENCE 9

This course has three major units: Life Science – reproduction from cellular to organism level

Physical Science – electricity and power (Physics) and chemical compounds, and periodic table and reactions (Chemistry)
Earth & Space Science – studying universe and solar system, earth-moon system. The course will utilize a variety of learning strategies such as laboratory work, projects and small group work.

SCIENCE 10

The course has three major units: Life Science – sustainable ecosystems; Physical Science: Chemistry – chemical reactions and radioactivity; Physics – Kinematics (motion and forces); Earth Science – energy transfer and geologic processes. The course will utilize a variety of learning strategies such as laboratory work, projects and small group work. This course has a mandatory graduation program exam worth 20% of the final mark.

SCIENCE CAREERS CO-OP

This program is for students interested in exploring science-related careers and doing some enrichment/application activities to extend science concepts learned in the regular curriculum. There will be opportunities for hands on experience through field trips and work experience. Students need a minimum letter grade of C+ in Science 10 in order to apply and to have demonstrated good work habits. In grade 11, students take

their science and work experience courses together as a group in Semester II, so that when they do their 3-week work experience they do not miss regular class time. The grade 12 year is scheduled with the normal flexibility.

Semester 1 - Grade 11

- English 11 - 4 credits
- Social Studies 11 - 4 credits
- Math 11 - 4 credits
- Language or Physics 11 or a Fine Arts Course - 4 credits

Semester 2 - Grade 11

- Biology 11 - 4 credits
- Chemistry 11 - 4 credits
- Independent Study Biology 12/Chemistry 12 - 4 credits
- Career Preparation Work Experience 12 - 4 credits

Note: The co-op is blocked into the timetable for blocks B-E. This leaves block A available for an elective if necessary. In Grade 12, students take 1 science 12 course to complete the WEX program as well as other courses required for graduation and post-secondary entrance.

BIOLOGY 11

This course is designed to introduce students to the diverse adaptations and ecological relationships in a variety of living organisms. The course will cover the following topics: microbiology, mycology, plant biology, animal biology and ecology with themes of evolutionary change throughout the course. Laboratory work is emphasized in this course.

BIOLOGY 12

This course encompasses two major topics of study: cellular biochemistry and human physiology. Cellular biochemistry focuses on cell organelles structure and function, biological molecules, DNA and protein synthesis. The human physiology portion emphasizes the interrelatedness between the major body systems: digestive, circulatory, respiratory, nervous, endocrine, excretory (urinary), and reproductive. It is **highly recommended** that students have success in both **Chemistry 11 and Biology 11 (a C+ or better grade)** before attempting Biology 12. This course has an optional

graduation program government exam worth 40% of final grade.

CHEMISTRY 11

Chemistry 11 is a lab-oriented course that will introduce students to scientific methods of experimentation. The topics include: study of atoms, molecules, matter, chemical reactions, solution chemistry and organic chemistry. A strong background in Mathematics would be beneficial in this course.

CHEMISTRY 12

Chemistry 12 builds on concepts covered in Chemistry 11 and emphasizes the interaction of atoms, molecules, and ions. The course covers the study of Reaction Kinetics, Chemical Equilibrium, and Oxidation-Reduction. The concepts are reinforced through laboratory work. Through this investigation, students will gain an increased understanding of the importance of chemistry in the modern world. This course has an optional graduation program exam worth 40% of the final grade. **It is highly recommended that students finish Chem 11 with a minimum 68% before selecting Chem 12.**

EARTH SCIENCE 11

This is a survey course designed to introduce students to the diverse aspects of earth and space science. The main organizing units are Earth and its Environment, Geologic Science, Oceanographic Science, Astronomical Science, Atmospheric Science, and Earth History. The course has a significant hands-on component aimed at developing both knowledge and the various skills of science.

ASTRONOMY 11

Does the universe fascinate you? Do you feel comfortable using computers? Then this course may be for you. We'll use the Internet to seek out information on a variety of Astronomy topics. We'll take a virtual tour of the solar system, learn the history of astronomy and the space program, attempt to understand the Universe's formation, contents and ultimate end. We'll physically build a telescope, have observing evenings and

take field trips. Instructor contact will be face-to-face as well as in on-line discussion boards and email. Interested students need to be self-motivated, enjoy group work and have a strong academic background. Students would benefit from having a computer and Internet access at home but this is not required.

GEOLOGY 12

This course is organized through the following units – Earth Materials, Surficial Processes, Time and the Fossil Record, Internal Processes and Structures, Resources and Comparative Planetology. It is a systematic and integrated study of the dynamic Earth through both theory and practice with both a local B.C. and extended world perspective. The course has a significant hands-on component aimed at developing both the knowledge and the various skills of science pertaining to the Earth. This course has an optional graduation program exam worth 40% of the final grade.

PHYSICS 11

In Physics 11 students develop and use mathematics tools and experimentation to study the nature of motion and the forces affecting motion. These are extended to the study of gravity, inertia, momentum and conservation of energy. The course also gives an overview of the nature of light, waves, relativity, time and nuclear physics.

PHYSICS 12

Physics 12 is designed to provide students with grounding in the discipline of physics. The treatment of the core topics is more rigorous mathematically than in Physics 11. As well, there is a greater emphasis on the use of logical, analytical inquiry when dealing with the subject matter. Because of this detailed treatment, the range of topics is limited to two general areas – mechanics and electromagnetism, as follows: vector math, motion in two dimensions, universal gravitation, charges and currents, electro-magnetism, and atomic physics. This course has an optional graduation program exam worth 40% of the final grade.

SCIENCE & TECHNOLOGY 11

This course allows the students to explore science and its application through technology. Students will study the following topics through a "hands-on" approach: Human Biology, Genetics, Forensic Science, Energy Resources and Computers Technology. Students will discover that technology opens up debates about our moral and ethical responsibilities, and students will pursue these issues and use the knowledge gained to consider decisions for future. Lastly, students will be presented with challenges and using their own problem-solving skills, will have to rise to meet the challenges.

SOCIAL STUDIES

SOCIAL STUDIES 9

Students will study the development of Canada from pre-contact First Nations peoples, to the history of early contact between Europeans and natives. They will also study some European history, especially the concept of revolution as illustrated through the English Civil War and the French and Industrial Revolutions. Other topics include the geography of North America and some mapping.

SOCIAL STUDIES 10

Students study Canadian history in the 19th century, with a focus on nation building: immigration, rebellions, Confederation, the development of the West, the history of British Columbia economy. Throughout their studies, students will consider the various conflicts between Canada's peoples (First Nations, first European immigrants) arising from this time period, and relate these to current issues facing these same groups of Canadians today. Students will also be introduced to the Canadian economy, and they will continue to learn about Canadian geography.

SOCIAL STUDIES 11

This course focuses on the development of citizenship skills and the preparation of students to take part in Canadian democracy. In history, they will learn about 20th Century Canada in relation to world affairs, such as the World Wars, the

depression, our place in the United Nations, etc. They will also study government, law, geography and the environment. The students will begin to develop an understanding about Canadian political and social issues. This course has a mandatory graduation program exam worth 20% of the final grade.

SOCIAL STUDIES 11 HONOURS

This course provides students with all the learning outcomes for the grade 11 curriculum. However, students will have the opportunity to explore major topics and issues related to the curriculum in greater detail especially through the use of case studies, debate, field study and group inquiry. This course aims to challenge the students with greater intellectual examination of current events that fit the SS 11 curriculum. This course has a mandatory graduation program exam worth 20% of the final grade.

CIVICS 11 (New!)

This course is open to all students in grade 11 or 12. The course goals are to enhance students' abilities and willingness to participate in civic life. **Civics 11 examines in detail the system of government in Canada and the citizens' participation and relationship with it. Areas that will be covered include democratic decision-making, political parties in Canada, political ideologies, the Constitution, the Charter of Rights and Freedoms, citizenship in the global community, beliefs and values, and current events.** This course has a mandatory graduation program exam worth 20% of the final grade. This course is recognized as a Social **Studies 11 credit.**

HISTORY 12

Strongly Recommended: Social Studies 11 (a "B" standing or better is strongly recommended)

History 12 is an in-depth study of major 20th century world affairs from 1919-1991. The course content begins with the Paris Peace Conference and the immediate post-World War I world and ends with the Gulf War and the decline of Communism in Eastern Europe in the early 90's. Students will examine the major events,

trends and personalities from this turbulent century, as well as developing fundamental skills needed to study History and properly understand the past. History 12 is a challenging, interesting and important course with an emphasis on critical thinking, communication skills (written and oral) and citizenship. This course has an optional graduation program exam worth 40% of the final grade.

B.C. FIRST NATIONS 12

This course has a British Columbia focus. Students will have an opportunity to develop an understanding of and appreciation for First Nations values, beliefs, customs and traditions. The past, present and future of First Nations will be examined along with the changes that have impacted on traditional First Nations' ways of life. A key purpose of the course is to increase students' awareness of cultural differences. It is important to note that ALL students enrolled in this course are REQUIRED to write a mandatory graduation program exam worth 20% of the final grade.

COMPARATIVE CIVILIZATION 12

Art, architecture, writing, religion, technology and government are used to explore ancient civilizations including, Africa, Mesopotamia, Egypt, Greece, and Rome. This is a hands on course with many opportunities for student to choose areas of interest and how they will demonstrate their learning. This is a great background course for students interested in all areas of History, Literature, as well as archaeology, and art history. There is no mandatory graduation exam with this course.

GEOGRAPHY 12

Strongly Recommended: Social Studies 11 with a "B" standing or better

Physical processes that affect the earth in the past, present and future form the basis of this course. Topics include plate tectonics, volcanism, earthquakes, erosion, climate, weather, map skills, vegetation, and soils. The discussion of these topics leads to an understanding of resources and resource management and man's interaction with an ever-changing

environment. Course study includes numerous tests and assignments as well as lab and field studies work. This course will form an excellent background for future studies or occupation in the field of geography. This course has an optional graduation program exam worth 40% of the final grade.

LAW 12

This course is open to grade 11 and 12 students. The course will provide a comprehensive look into law and the legal process, particularly as they relate to the Canadian justice system. In addition to discussing the basic components of the law, the course will explore some of the major legal issues facing Canadians, including: the parole system; young offenders and juvenile justice; legal implications of physical and sexual child abuse; constitutional rights under the Charter; children's rights; forensics; women's rights. Field trips, guest speakers, films, and documentaries all add to the course. Students will analyze actual legal cases utilizing decision-making techniques with their legal knowledge to determine case outcomes.

Note: No government provincial examinations are offered in this course.

PSYCHOLOGY 12 (BAA)

This course is the scientific study of human behavior and mental processes. Students will gain insight into the brain, our senses, consciousness, learning, memory, motivation, lifespan development, and personality development. This course will be of interest to students who are considering careers in education, law and mental health.

AP PSYCHOLOGY 12 (Advanced Placement)

This is a **University level course** which prepares students to write the AP exam in May. Successful completion of the AP exam can result in the student receiving credit for first year University Psychology at many educational institutions. The focus for this course is the scientific study of human behavior and mental processes. AP Psychology moves at a very fast pace and will cover additional chapters as compared to Psychology 12. This class is

best recommended for mature, self-motivated academic students. Students considering this course should have a minimum B standing in grade 11 Socials, English and Science courses.

SOCIAL JUSTICE 12

This elective course is open to all students in grade 11 and 12. It will focus on social justice issues. There are three main focus areas: Defining Social Justice, Recognizing and Overcoming Social Justice, and Creating a Socially Just World. The aim of the course is to increase the understanding of communication between and among people from different racial, ethnic, ability, religious, cultural, gender, sexual orientation and socio-economic class backgrounds. There is no graduation program exam for this course.

STUDENT SUPPORT SERVICES

NOTE: Students in need of Student Services support are referred to these courses via the School-Based Team by classroom teachers, counsellors, administrators, or parents. Priority placement is given to students with diagnosed learning disabilities (according to need). Others who are experiencing difficulty may be scheduled into these courses, or may drop in for extra help (after consultation between the classroom teacher and the LC).

LEARNING CENTRE 9, 10, 11, 12 (NON-CREDIT)

This course is taken in place of an elective, or in some cases in place of a specific course depending on the student's IEP.

Support can include:

- Academic skill development instruction.
- Learning, organizational, test-taking/study strategies instruction
- Where student learning needs warrant it, provision of alternate adapted or modified materials, self-paced curriculum, partial day schedule, small group instruction, or

computer-based courses in place of regular class instruction

- Time and assistance to complete homework, review / clarify course concepts, prepare for tests, and write missed class exams.

SKILL DEVELOPMENT PROGRAM 9-12 (NON-CREDIT)

The Skill Development Program offers integrated instruction and small group or 1 to 1 academic and life skills instruction for students with identified significant special learning needs. Access to this program is via District #43 screening only.

PEER TUTORING 11, 12 BAA

Peer Tutoring 11 and 12 are courses available to recommended students who enjoy helping others, attend regularly, and are conscientious students. Initial training will occur outside the regular timetable at the beginning of each semester. All students are required to keep progress notes and meet the course evaluation criteria to earn credit. Students who do this course as Grade 12 are expected to do an additional written assignment and more challenging support assignments to demonstrate their skills in helping others.

TRADES & TECHNOLOGY EDUCATION

Technology Education provides students with skills necessary to explore the realm of technological fields in our society. Students are given the opportunity to design, create and construct using tools, machines and materials. Processes and problem solving will be emphasized at all levels of planning and fabrication. The technical courses also prepare students for the post secondary vocational field and encourage them to become lifelong learners in a world of changing technology. Students may also pursue several areas in depth by taking the Career Preparation Program in carpentry-joinery, mechanics or drafting. We also offer the high school apprenticeship program in Automotive Service Technician and Carpentry-Joinery as well as the Automotive Service Technician Level 1 (Ace-It) Program.

APPLIED TECHNOLOGY

TECHNOLOGY 9

Woodworking, Metal Work, Drafting & Design, Electronics and Basic Mechanics are the core areas of Technology Education. This course is designed to allow students to explore as many of the Technology Education areas as possible while developing an understanding of the technological and computer concepts that are used as they design, develop and build hands-on products and service mechanical devices. **This course forms the foundation to further pursue courses in the Trades & Technology Department.**

TECHNOLOGY 10: ELECTRONICS

This course will provide students with an introduction to electronics. Students will use a variety of electrical equipment to build a number of interesting electrical projects. Course emphasis will be divided between basic electrical theory and hands-on project work.

APPLIED TECHNOLOGY EDUCATION 10

Building on the concepts covered in Applied Technology 9, this course will allow students to discover manufacturing processes and methods of problem solving while working through hands-on activities. The areas of design, metalwork, plastics, woodwork projects. This course will prepare students for future Technology 11 courses.

DRAFTING & DESIGN

TECHNOLOGY 10: DRAFTING & DESIGN

This course is designed for students interested in drafting careers such as; engineering, interior design, industrial design, architecture, carpentry, steel fabrication, cabinet making, electrician, plumbing, heating or any one of the numerous other professions which demand knowledge of drafting. The students will explore the elements and techniques used for sketching, designing, modeling and creating mechanical and basic architectural drawings. This course covers the basics of board drafting then quickly moves on to 2-D Computer

Assisted Drafting and Design (CADD) using AutoDesk AutoCAD software. Students will be given the opportunity to create artistic CADD designs which may then be produced as vinyl decals, T-Shirt heat transfers or machined on our CNC equipment. Students will be expected to create a Portfolio of their work in analog or digital format.

DRAFTING & DESIGN 11

Strongly Recommended: Drafting and Design 10

This course is designed for students interested in exploring careers such as drafting, engineering, interior design, industrial design, architecture, carpenter, steel fabricator, cabinet maker, electrician, plumbing, heating or any one of the numerous other professions, which demand knowledge of drafting. Building on the concepts learned during the Level 1 Drafting course (Drafting & Design 10) students will explore the elements and techniques used for sketching, designing, modeling and creating mechanical and basic architectural drawings. This course will allow the student to focus their learning in either Mechanical or Architectural Drafting using both manual and Computer Assisted Drafting and Design techniques. Students will be expected to create a Portfolio of their work in analog or digital format.

DRAFTING & DESIGN 12

Strongly Recommended: Drafting & Design 11

Building on the basics of Drafting & Design 11, this intermediate-advanced level course focuses on the development of skills and practices common to a draftsman, architect, engineer, surveyor, and scientist. This course is designed for the student interested in technical illustration and other drafting careers.

DRAFTING & DESIGN 12: ARCHITECTURAL & HABITAT DESIGN

Strongly Recommended: Drafting and Design 12 (Concurrent enrolment is permissible)

This course will allow students to advance their existing drawing skills and an opportunity to design house plans and elevations. Sketches of buildings and floor

plans will be converted to computer drawings using Autocad, 3D Studio VIZ, and Home Architect. Students interested in interior design or house construction will be able to layout concepts in 2D and 3D drawings.

DRAFTING & DESIGN 12: ENGINEERING & MECHANICAL DRAFTING

Strongly Recommended: Drafting and Design 12 (Concurrent enrolment is permissible)

This course will provide experienced students time to explore engineering topics of their choice. They will use a variety of software and drawing techniques to show details of mechanical drawings. Computer generated walk-throughs and 3D models will enhance their selected topics. Major software and CNC machining will provide the engineering/ lab component.

DRAFTING AND DESIGN 12: TECHNICAL VISUALIZATION

Strongly Recommended: Minimum of Drafting & Design 12 (Concurrent enrolment with Instructor permission) – Strong Recommendation that students enroll in Architectural & Habitat Design or Engineering & Mechanical Drafting (Concurrent enrolment is permissible)

Technical Visualization typically utilizes computer-generated models, animation and rendering to provide learning opportunities for students to perceive, respond to, and create still or moving images of a technical nature, using technical knowledge, skills, and tools. It is a means to study a design and/or tell a story, not a technical exercise in using computers. This specialized course allows the student to develop the personal attributes and skills to explore possible career paths in technical visualization, animation, or industrial design in the context of Drafting and Design. Since the curriculum is offered in a hands-on environment, students will produce samples of their work, which will serve as portfolio examples while they explore career opportunities.

WOOD TECHNOLOGY

TECHNOLOGY EDUCATION 10: WOODWORK

This course provides an opportunity for students to work creatively with a variety of woods. Safety will be taught through the use of hand and simple power tools. Students will use band saws, sanders, and jigsaws to explore ways that wood can be laminated and shaped into esthetically pleasing and functional projects (e.g. Heritage Stool, Rolltop Breadbox and skateboard decks).

CARPENTRY & JOINERY 11

Recommendation of Wood 10

This course is an introductory woodwork course offering approximately 110 hours in building personal, practical projects. It involves the use of machines, portable electric tools and finishing equipment. Projects such as oak coffee tables, stereo stands, entertainment centers, desks and speakers are some of the choices available. Students are expected to pay for the project material. (AS)

CARPENTRY & JOINERY 12

Strongly Recommended: Carpentry and Joinery 11

This course is structured to provide advanced use of woodwork machines and procedures. Special skills and set-ups will be used in the production of projects for personal use. Payment for project materials is required. (ASK)

CARPENTRY & JOINERY 12: CABINET CONSTRUCTION

Strongly Recommended: Carpentry and Joinery 12

This course is structured to study and practice cabinetry and millwork procedures. The study of the design and construction of fine furniture will be emphasized. Projects including oak chests, entertainment units, grandmother clocks, classic oak desks, ocean kayaks and other personal projects will be considered. Mass production techniques will also be included where applicable. Students are expected to pay for much of the material they use. (ASK)

CARPENTRY & JOINERY 12: RESIDENTIAL CONSTRUCTION

Strongly Recommended: Carpentry and Joinery 12

This course is designed to study the construction industry, particularly house construction. Construction materials and machine operations (including the use of portable tools) are included. Practical experience in framing, layout and construction is part of the course program. Some time for personal projects may be available. (ASK)

CARPENTRY LEVEL 1 – TERRY FOX SECONDARY PROGRAM

This post-secondary program is part of the Industry Training Authority ACE-IT initiative, and is open to Grade 12 students intending to pursue a career as a Red Seal Carpenter. Students will take 4 courses in the second semester and then complete 4 weeks at Kwantlen Polytechnic University from mid June to early July. Students will earn 16 credits towards graduation and will write the Level 1 exam. A 70% grade on this exam will qualify the students to progress to Level 2 training when requirements for apprenticeship training hours are requirement are met. Work Based training will be an integral part of this program, and must be completed by September 30th of the graduation year (students can earn anywhere from 8 to 16 credits as part of the work experience component). This program is designed for motivated students with a career focus and will provide excellent Apprenticeship placement advantages for successful students. Open to all District 43 students having the following:
Math 11 (if Essentials, C minimum)
Carpentry and Joinery 11 recommended
Physical Ability to do the job.

Enrolment in this program will be limited to 18 students per year, and admission will be by application. The application process will include an interview and a review of attendance records as well as recommendation from a teacher. Applicants will need to have their courses programmed in such a way as to have their required Grade 12 courses completed by the fall semester.

METALWORK

METAL FABRICATION & MACHINING (FNASK) 11/12

(ART METAL & JEWELRY)

This course is designed for students to learn metalwork techniques in the construction of projects. Emphasis will be on creativity and design prior to building. Students will learn to use drill presses, lathes, grinders and welding equipment, along with sheet metal and hand tools throughout the semester. (ASK)

METAL FABRICATION & MACHINING 11/12

This course involves general metalworking and the study of various branches of the metal working industry. The course involves theoretical and practical studies in the following areas: design, bench work, shop sketching, oxy-acetylene and mig welding, and machine operations. After completing the basic requirements of the course, students may study or complete projects in any area of metalwork under the guidance of the teacher. Basic supplies are provided, however, the student should expect to pay for project materials.

METAL FABRICATION & MACHINING 12: ADVANCED FABRICATION

Strongly Recommended: Metal Fabrication & Machining 12

This course will use a variety of welding and machine tool operations, which may include computerized machining in advanced fabrication project work, including design, material selection, cost estimation, time allocation and the building of advanced projects.

METAL FABRICATION & MACHINING 12: ADVANCED WELDING

Strongly Recommended: Metal Fabrication & Machining 12

This course builds on the various welding processes studied in the requisite Metalwork courses. Students will be producing a number of advanced welds using a variety of techniques, equipment and procedures. Emphasis is placed on operational and safety knowledge of the procedures and related equipment and tools while the student develops the techniques to produce quality welded joints through a range of advanced project work.

AUTOMOTIVE TECHNOLOGY

TECHNOLOGY EDUCATION 10: MECHANICS

This course focuses on the human discovery and use of alternate energy sources that provide us with transportation and home comfort. It will involve teamwork, problem solving, basic mechanics as well as individual assignments. Students will study the principles of 2 and 4 stroke engines to provide a basis for Automotive Technology 11. (ASK)

AUTO MAINTENANCE 11 (B/G) BAA

This course is designed to provide the future owner/driver with a basic working knowledge of the mechanical functions of the modern automobile. The practical work and demonstrations will cover the basic routine maintenance, repair and safety checks required to keep your vehicle in proper running order. NOTE: This is a BASIC COURSE ONLY, it is consumer oriented, covering the operating, maintaining and purchasing of an automobile. It is not intended as a Strongly Recommended for subsequent Automotive Systems courses. (ASK)

AUTOMOTIVE TECHNOLOGY 11

*Strongly Recommended:
Recommendation that students take Mechanics 10*

This course is designed as an introduction to the basic repair and maintenance procedures of the modern automobile. Students leave this course with a basic understanding of the working systems of the automobile, the tools used, and the industry-wide standards of safety, maintenance and repairs. (ASK)

AUTOMOTIVE TECHNOLOGY 12

Strongly Recommended: Automotive Technology 11

Building on Automotive Technology 11, this course will explore the theory and operation of advanced automotive systems. The student is expected to possess a high degree of competency in basic shop procedures and hands-on exercises with minimal instruction. The students will be expected to apply their

previous knowledge as they learn to diagnose and repair the more advanced vehicle systems that will be covered in Automotive Technology 12. (ASK)

AUTOMOTIVE TECHNOLOGY 12: ENGINE AND DRIVE TRAIN / AUTOMOTIVE ELECTRICITY AND ELECTRONICS (DOUBLE BLOCK)

Strongly Recommended: Automotive Tech12

This two-block course builds upon the concepts covered in Automotive Technology 11 & 12. Your previous knowledge and practical experience in the principles of Engine and Drive Train as well as Automotive Electricity and Electronics will be used to focus your learning on advanced theoretical and comprehensive practical applications. Emphasis is placed on becoming a well-rounded young adult through practical experience, theoretical knowledge, academic skills and strong personal organizational abilities. This course is strongly recommended for students wishing to pursue a career in the Mechanical Service Industry. (ASK)

AUTOMOTIVE SERVICE TECHNICIAN LEVEL 1 – TERRY FOX SECONDARY PROGRAM

This post-secondary program is part of the Industry Training Authority ACE-IT initiative, and is open to Grade 12 students intending to pursue careers as Red Seal certified Automotive Technicians. Students completing this full year, dual credit, four course (two per semester) program will receive 16 credits toward graduation and will write the Standardized Level 1 assessment exam. A 70% grade on this exam will qualify the student to progress to Level 2 training when requirements for Apprenticeship training hours are met. Work-based training will be an integral part of this program, and must be completed by September 30 of the graduation year (students can earn anywhere from 8 to 16 credits as part of the work experience component). This program is designed for motivated students with a career focus and will provide excellent Apprenticeship placement advantages for successful students. Open to all District 43 students

having the following Strongly Recommendeds:

1. Automotive Technology 11 and 12 (C+ minimum)
2. English or Communications 12
3. Math 11 (if Essentials, B minimum)
4. Physics 11 recommended
5. Working knowledge of computers
6. "L" drivers license

Enrolment in this program will be limited to 18 students per year, and admission will be by application. The application process will include an interview and a review of attendance records and will require a recommendation from the student's Automotive Technology 12 instructor. Applicants will need to have their courses programmed in such a way as to have completed all Grade 12 Strongly Recommended by the end of the Fall semester of their grade 12 year.

POST SECONDARY INFORMATION

POST SECONDARY EDUCATION AND TRAINING OPPORTUNITIES

Current labor market information indicates that the jobs of the future will require education beyond grade 12.

HIGH SCHOOL GRADUATION

Graduation from Terry Fox Secondary does not automatically guarantee entrance to a post secondary institution.

Students are responsible for determining the exact entrance requirements of the institution they wish to attend.

OPTIONS

In British Columbia students graduating from high school have a wide range of choices for post secondary training.

These include:

- Technology and Trade Schools and Apprenticeship programs
- Community Colleges
- Universities
- Specialty Universities/Institutes (e.g.: Emily Carr and The Justice Institute)
- Private Training Schools

Students may choose to enter university directly or they may take their first and/or

second year of a university program at a local college. If they obtain the required GPA they may then transfer to second or third year university. There are many advantages to completing the first year or two at a local college.

HOW DO I GET IN?

Complete and current information is maintained in the Career Center regarding all public post secondary education/training facilities in B.C. In addition information on many private training schools is also available.

The following steps will help you plan a smooth transition from high school to post secondary education/training:

- Check with your counsellor to determine that you **will** graduate.
- Make an appointment with the Career Resource Facilitator in the Career Centre to ensure that you have the pre-requisites for the specific program you wish to enter.
- Apply to the institution(s) of your choosing by internet (available in the Career Centre). Some colleges still accept paper applications.

Applications for post secondary institutions may begin as early as October or November of the year prior to your entering a post secondary institution.

Appropriate application fees must accompany all applications. A Post Secondary Institutions (PSI) Selections Form must be completed online no later than April 30, 2011. Some institutions may request a student to self-report their grades online or may request an official paper transcript. See your counselor for a Transcript. Once you have applied and met all the requirements you may:

- be offered conditional admission (your final transcript will be reviewed)
- not be offered admission

Registration is the process you will go through either using the internet or over the phone with a course planner at the institution you will attend after you have accepted your offer of admission. If you have any doubts about your program plan you should make an appointment with an

academic advisor at that specific institution.

CO-OPERATIVE EDUCATION

Gain a slight edge in University! The job market you enter is very competitive. Participating in CO-OPERATIVE EDUCATION will give you a combination of academic preparation along with paid work experience in a business, industry or a branch of government. For detailed information contact the CO-OP Coordinator at the institution of your choice during your first year of university. Make things happen by design...not by accident!

INTERNATIONAL EXCHANGES

Most universities offer international educational exchange programs with many overseas institutions. In many cases you pay local tuition fees while attending an international school. Contact the exchange office at the university of your choice.

POST SECONDARY INSTITUTIONS

Every effort is made to provide information which is as current as possible. However the final responsibility remains with the student to ensure that both general and specific entrance requirements are met.

(SAT) SCHOLASTIC APTITUDE TEST EXAMINATIONS

Students should be aware that American Universities and Colleges require a College Entrance examination score (S.A.T.) This examination should be taken early in the Grade 12 year. Grade 11 students who wish to attend an American Universities or Colleges should take the

P.S.A.T. examination offered at Terry Fox beginning early October.

LANGUAGE PROFICIENCY INDEX (LPI)

Most BC colleges and universities require students to take an English placement exam. Terry Fox Secondary may host a sitting for this exam. The exam date is April 19, 2011. Visit www.lpi.ubc.ca for further information.

ESL STUDENTS

Many institutions require ESL students to take a TOEFL/IELTS or other such test prior to admission. Check to see which applies to your situation.

BC MINISTRY OF EDUCATION

Information re: graduation, external courses & equivalency.

Contact

<http://www.bced.gov.bc.ca/graduation>

BC PUBLIC POST SECONDARY INSTITUTIONS

There are several degree granting universities in BC. Among them are the traditional universities such as:

- University of British Columbia UBC (Vancouver & Okanagan)
www.you.ubc.ca/vancouver
www.you.ubc.ca/okanagan
- Simon Fraser University SFU (Burnaby & Surrey)
www.sfu.ca
- University of Victoria
www.uvic.ca

- University of Northern BC
www.unbc.ca

There are also several universities that offer a combination of career, trades and technology programs as well as degree programs such as:

- Capilano University
www.capilano.ca
- Kwantlen Polytechnic University
www.kwantlen.ca
- Thompson Rivers University
www.tru.ca
- University of the Fraser Valley
www.ufv.ca
- Vancouver Island University
www.viu.ca

Emily Carr University of Art & Design
www.ecuad.ca specializes in undergraduate education in art, design and media.

Trades & Technology in our area are located at the British Columbia Institute of Technology (BCIT) www.bcit.ca and at Vancouver Community College (VCC) www.vcc.ca

Douglas College www.douglas.bc.ca is our closest regional college, but some of our students are interested in specialty college programs offered at Langara College www.langara.bc.ca and Vancouver Community College www.vcc.ca. Regional colleges offer some applied degrees and career programs of one or two years in length, as well as university transfer which permit transfer to a BC university into second or third year.

BC POST SECONDARY ADMISSION REQUIREMENTS

Each college and university in Canada has DIFFERENT admission requirements and students must check with each institution carefully. Institutions do not require students to write optional provincial exams. If a grade 12 provincial exam is written, most universities will take the higher of the course grade or blended final grade into the admission average. Check with the Career Centre for more info. Some university programs are competitive and require a minimum GPA. Please check with each institution carefully

The following is a list of some **BC Post Secondary Institution Admission Requirement Web Links:**

UBC (Vancouver):	https://you.ubc.ca/ubc/vancouver/bcyt.ezc
UBC (Okanagan):	https://you.ubc.ca/ubc/okanagan/bcyt.ezc
SFU:	http://students.sfu.ca/admission/requirements
UVIC:	http://registrar.uvic.ca/undergrad/admissions/requirements/bc.html
Emily Carr:	www.ecuad.ca/admissions/undergrad
Douglas College:	http://www.douglas.bc.ca/calendar/general-information/admissions.html

For other post secondary options in BC: www.educationplanner.ca.

APPLICATION TO POST SECONDARY INSTITUTIONS in BC & Canada

BC Post Secondary Application Service.....	www.pas.bc.ca
Alberta College & University Application Service.....	www.applyalberta.ca/pub/
Ontario University Application Centre	www.ouac.on.ca
Ontario College Application Service.....	www.ontariocollege.ca
Other Canadian Colleges & Universities:	go to post secondary institution website to apply online.

***NOTE** Deadlines for applications vary for Sept. entry for **each** post secondary institution.

Check each institution or application site for verification. Students are welcome to receive assistance in the Career Centre.

Transcripts

Once you have applied to the post secondary institution you are considering attending, you must complete an online Post Secondary Institutions (PSI) Selections form in order for official transcripts to be sent electronically to each post secondary institution. Login at <https://www.bced.gov.bc.ca/exams/tsw/tsw/student/>. **The deadline is April 30, 2011.** In addition, some BC institutions require you to self-report your grades. They will instruct you. Some universities outside of BC may require an official paper transcript. See your counsellor for a copy.

OTHER USEFUL WEB SITES

Apprenticeship.....	www.itabc.ca
BC Transfer Guide.....	www.bctransferguide.ca
The Association of Universities & Colleges of Canada.....	www.aucc.ca
Colleges & Universities in BC, Canada, US & International	www.uwaterloo.ca/canu
US Colleges & Universities	www.utexas.edu/world/univ

US Colleges & Universities/SAT Registration:

TAKING THE SAT TEST for US Colleges & Universities

Online registration is the simplest and quickest way to register. Go to <http://sat.collegeboard.com>

Registration Information:

Country code: 651	High school code: 821273
Test Centre Codes:	<u>94463</u> <u>94484</u>
Matthew McNair Secondary 9500 No. 4 Road Richmond (604)668-6575	Prince of Wales Secondary 2250 Eddington Vancouver (604)736-2661

You will need to pre-register for the following test dates:

<u>Registration Deadline</u>	<u>Test Date</u>
-------------------------------------	-------------------------

April 8, 2011
May 6, 2011

May 7, 2011
June 4, 2011

SCHOLARSHIP WEB SITES

Entrance Scholarships

UBC Okanagan.....	https://you.ubc.ca/ubc/okanagan/finances.ezc?pageID=1074
UBC Vancouver.....	https://you.ubc.ca/ubc/vancouver/finances.ezc?pageID=1028
SFU.....	http://students.sfu.ca/entrancescholarships/index.html
UVIC	http://registrar.uvic.ca/safa/scholarships/entrancescholarships.html
BCIT.....	www.bcit.ca/finaid/
Douglas College.....	www.douglas.bc.ca/services/financial-aid/forms.html

External Scholarships

Aboriginal Scholarships.....	www.ammsa.com/bursary-national2.html
Scholarships, Bursaries & Awards for BC Students.....	http://www.bcawardsonline.org/
Canadian Scholarships.....	www.scholarshipscanada.com
.....	www.studentawards.com
.....	www.studentscholarships.org

BC Government Scholarships & Awards	www.bced.gov.bc.ca/awards/
--	--

Financial Aid

BC/Canada Student Loan Application.....	www.studentaidbc.ca
Government of Canada Financial Aid.....	www.canlearn.ca